

CONCEPT Isolator



Excellent short circuit ratings - Icu 25kA

Market leading Selectivity levels

Suitable for Concept Panelboard's
(COE, CPL, CPR)

Suitable for connecting to NC and GB
isolation chassis

Position indication or remotely trip with
optional accessories

Providing reliability of supply at higher
fault levels



Concept Isolator Switch Kit

ICB	NC Chassis - Cat No	GB chassis - Cat No
160A	CEL3160MK	CEL3160MKGB
250A	CEL3250MK	CEL3250MKGB

Concept Isolator Selectivity

Downstream			Concept Isolator	With additional upstream MCCB
Brand	Model	Current rating A	CEL3160Mxx CEL3250Mxx kA	TBPRO A250, P250 kA
MOD6	MOD6 MCB	6-63	6	20
MOD6	MOD6RCBO1	10-32	6	20
MOD6	M6RCBS	6-32	6	20
DINT	DTCB6	2-63	6	20
DINT	DSRCBH6	6-40	6	20
DINT	DSRCBS	6-32	6	20
DINT	DSRCB..AI	6-40	6	20
DINT	DTCB10	0.5-63	10	25
DINT	DSRCBH	6-40	10	25
DINT	DSRCB	6-40	10	25
DINT	DTCB15	6-63	15	25
DINT	DTCB10H	80-125	15	25

Switch Kit contents

- Isolator switch
- Instruction sheet
- Chassis connection spacers
- Mounting & connection bolts
- Terminal covers (line and load)
- Interpole barriers

Ratings

- Breaking capacity 25kA Icu, 19kA Ics 415V AC (IEC 60947-2)
- Rated insulation voltage Ui 690V AC
- Rated impulse withstand voltage Uimp 8kV
- Utilisation Category A



Terminal cover standard



Terminal cover extended



Terminal cover wide

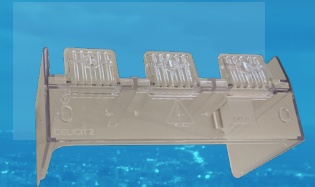

Terminal cover Isolator



Non-captive toggle lock



Flanged extension bars

Accessories

Terminal covers	Standard	T2CF25L3SSHP*
	Extended	T2CF25L3SLHP
	Wide	T2CF25L3SWHP
	Isolator to NC/GB chassis	CELICIT2*
Extension bars	Straight	T2FB25L3SH
	Flanged (larger lugs)	T2FB25L3WH
Toggle Lock	Non-captive	T2HL25L
	Captive	T2PL25LIP
Shunt Trip	230-240V AC	T2SH00LA20T
	400-415V AC	T2SH00LA40T
Auxiliary Switch	1 C/O	T2AX00LML3STA

* Supplied with kit

Dimensions (mm)

Escutcheon cut-out with chassis

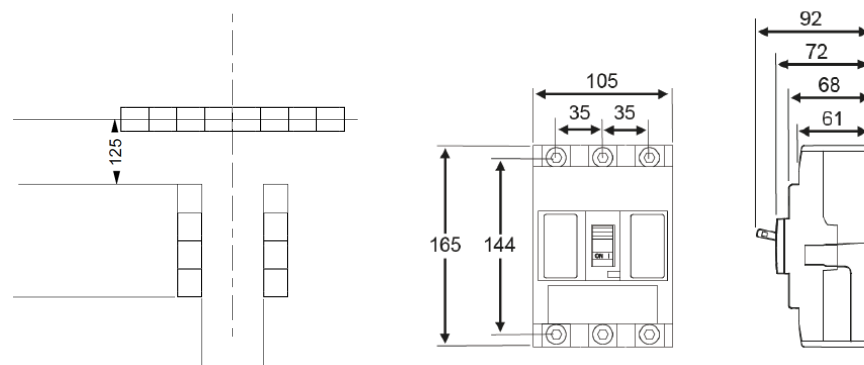

nhp.com.au
 SALES 1300 NHP NHP
 sales@nhp.com.au
 nhpnz.com.nz
 SALES 0800 NHP NHP
 sales@nhp-nz.com

NHP Electrical Engineering Products

A.B.N. 84 004 304 812
 © COPYRIGHT NHP 2021
 NHP13FLY 04/21