

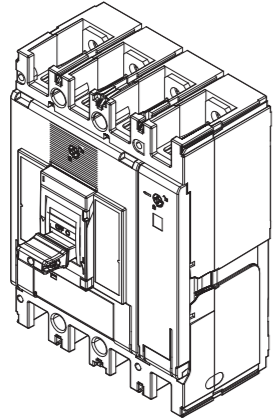

INSTALLATION INSTRUCTIONS MOULDED CASE CIRCUIT BREAKERS TEMBREAK PRO P400 4P SMART ELECTRONIC



NHP Electrical Engineering Products Pty Ltd
A.B.N. 84 004 304 812

AUS 1300 NHP NHP | nhp.com.au
NZ 0800 NHP NHP | nhp-nz.com

TOOLS REQUIRED (NOT included)

- T1 Screwdriver Flathead (5mm)
- T2 Screwdriver Phillips (#2)
- T3 19mm Socket wrench
- T4 8mm Allen key Socket wrench
- T5 19mm Ring Spanner

HARDWARE (included)

- A M10x30 Socket Screw (8 qty)
- B M10 spring washer (8 qty)
- C M10 flat washer (8 qty)
- D M6x100 mounting screws (4 qty)
- E Interpole Barriers (3 qty)
- Instruction Manual (This Document)

HARDWARE (NOT included)

- F Cable Lug or Copper Bar
- G *M12x35 hex bolt (8 qty)
- H *M12 flat washer (8 qty)
- I *M12 Belleville washer (8 qty)
- J *M12 nut (8 qty)

*For extension bar connection only

OPTIONAL (NOT included)

- K Extension Bars
- L Terminal Covers
- M Terminal Cover Lock
- N Handle Lock
- Internal Accessories

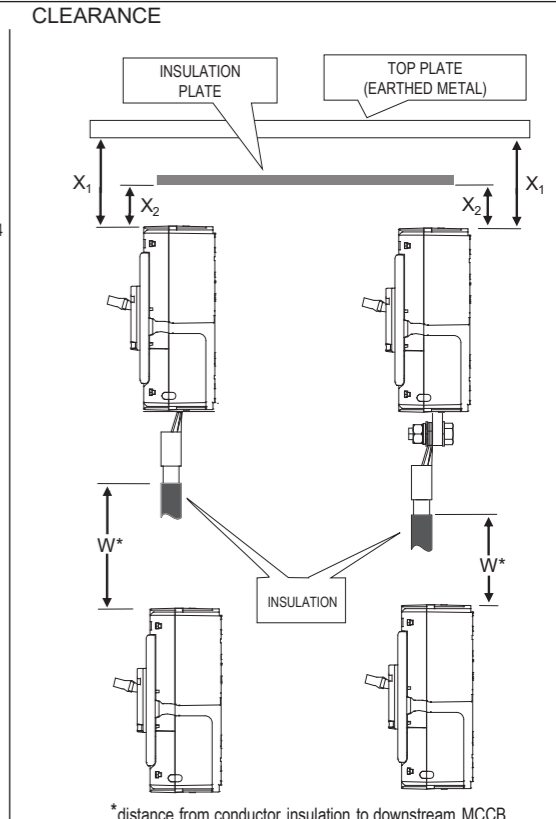
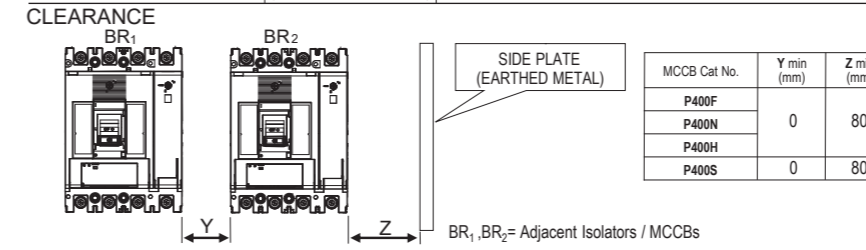
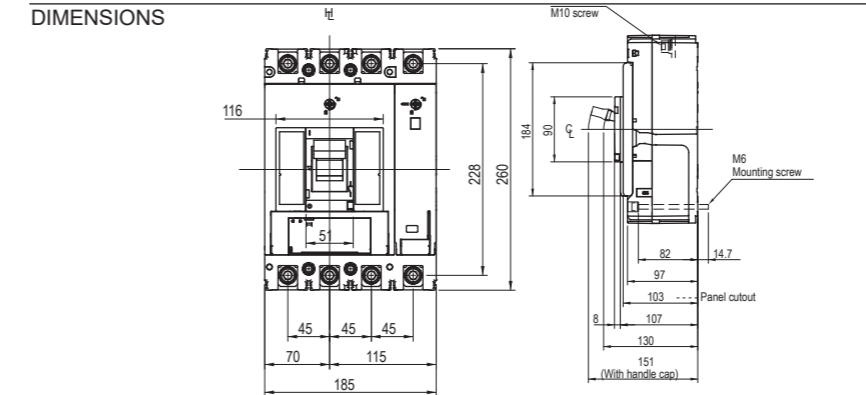
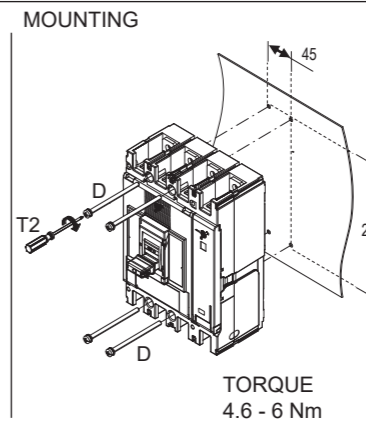
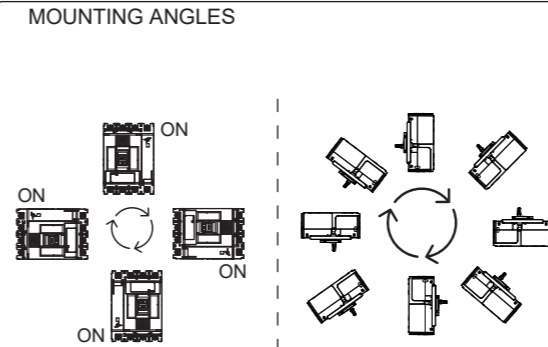

MCCB Cat No.	W* min (mm)	X ₁ min (mm)	X ₂ min (mm)
P400F			
P400N	100	80	60
P400H			
P400S	120	120	80

OPERATING INSTRUCTIONS

Operation Force (Nm)

Operation	Force (Nm)
OFF → ON	150
ON → OFF	130
TRIP → OFF	162

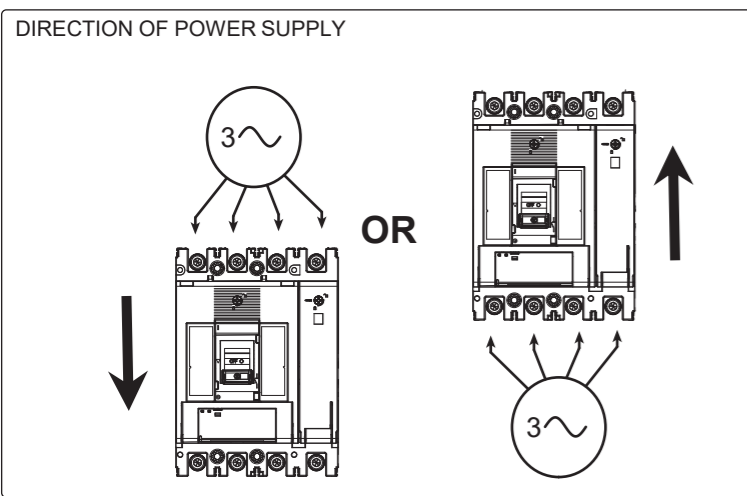

INTERNAL ACCESSORIES ASSEMBLY PROCEDURE*

STEP 1 TRIP MCCB

STEP 2 OPEN COVER

STEP 3 IDENTIFY TRIP BAR & MECHANISM

STEP 4.1 UVT/SHUNT INSTALLATION

STEP 4.2 ALARM INSTALLATION

STEP 5 CLOSE MCCB COVER

*For additional internal accessory installations, scan QR code and refer to user manual for more details

SMART AX/AL INSTALLATION PROCEDURE

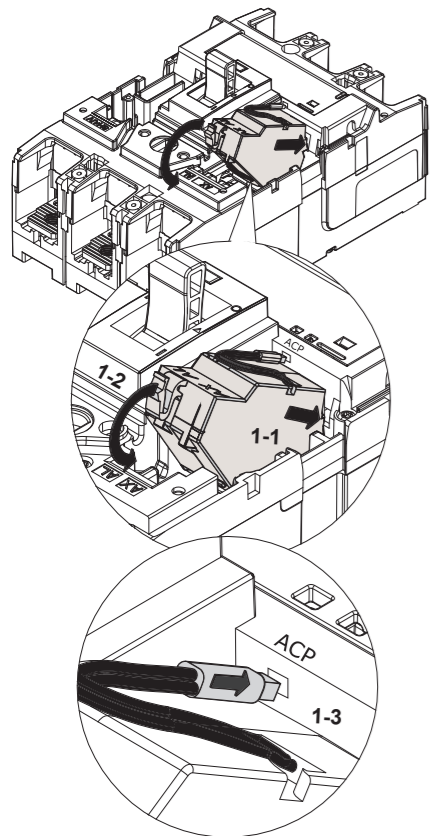

NOTE: SMART type AX/AL can only be installed in the LH side accessories chamber as shown above.

Follow steps 1,2 and 5 of 'Internal Accessories Mounting Procedure' to access and close the internal accessories chambers.

CONDUCTOR CONNECTION PROCEDURE -- FRONT CONNECTION -- EXTENSION BAR CONNECTION PROCEDURE

A	M10x30 Socket screw	H	M12 Flat washer
B	M10 Spring washer	I	M12 Belleville washer
C	M10 Flat washer	J	M12 Nut
F	Lugs or copper bar	K	Extension Bars
G	M12x35 hex bolt		

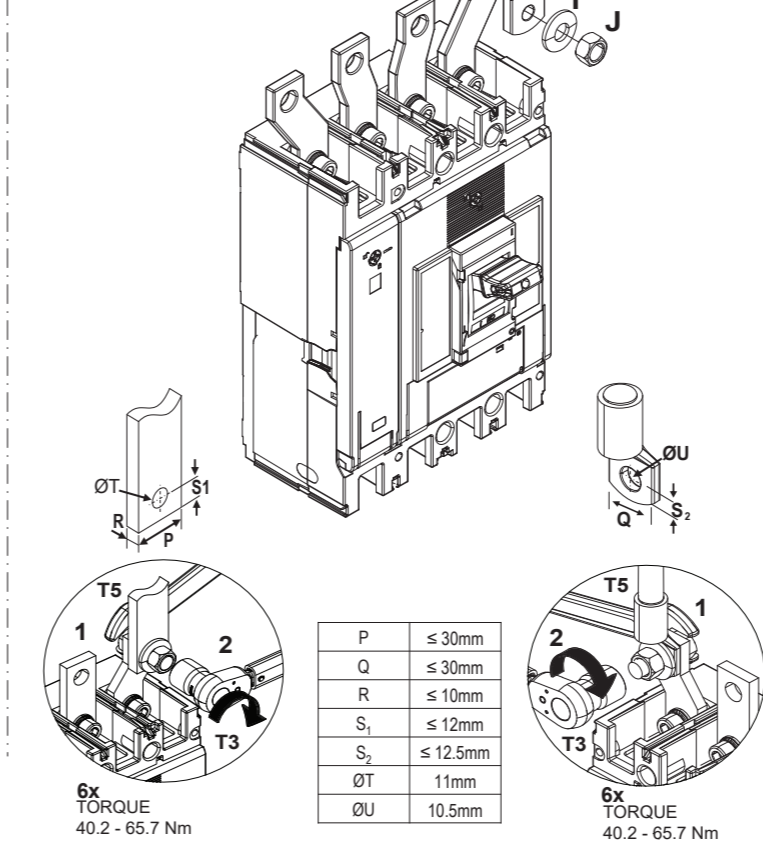
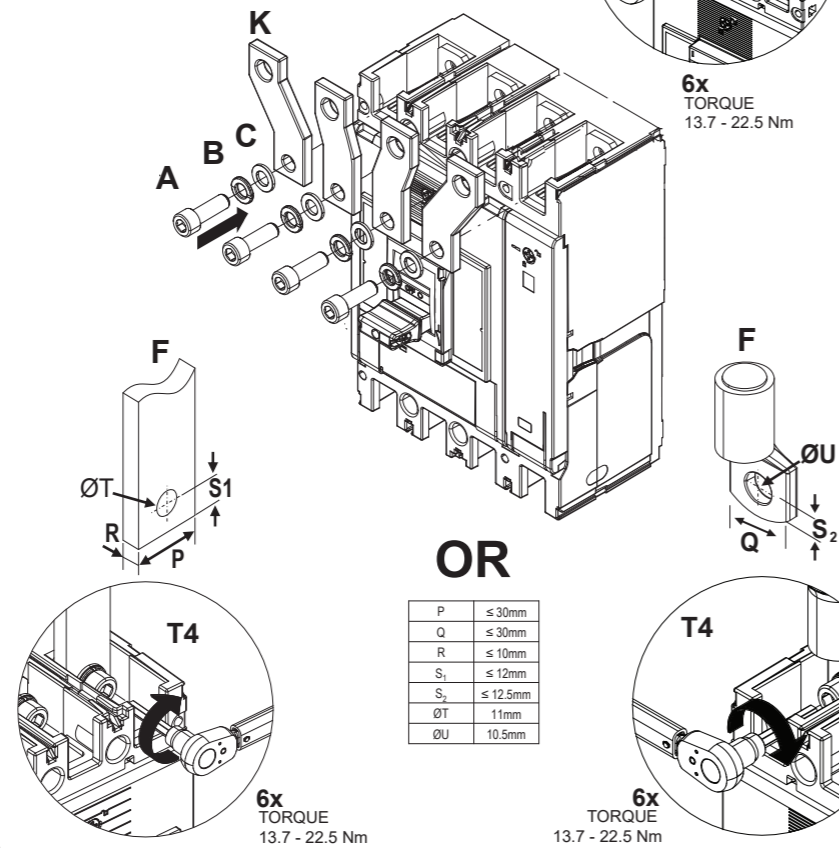

TRIP UNIT ADJUSTMENT PROCEDURE

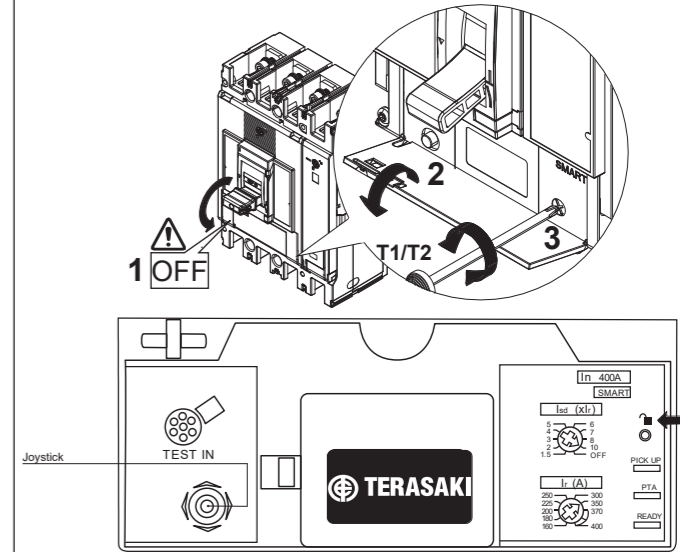

- NAVIGATION
- Adjust 'Ir' dial for desired rated current
 - To navigate between main menus, move joystick left or right
 - To navigate within a submenu, move joystick up or down
 - To confirm a setting change, press in the joystick

Protection	Measurement	Configuration	Information
DISPLAY ORIENTATION	STANDBY MODE	SCREEN BRIGHTNESS	

*By default, the SMART OCR Protection settings are protected via a locking function, to unlock, please press the unlock button

FOR MORE INFORMATION, PLEASE SCAN THE QR CODE

TERMINAL COVER MOUNTING PROCEDURE

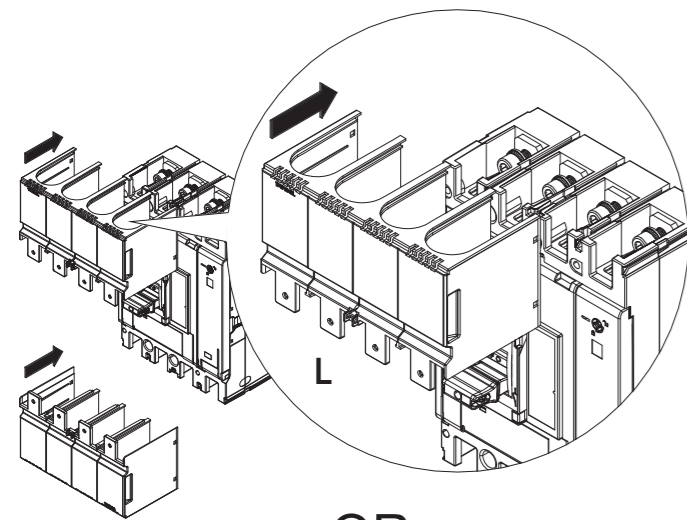

INTERPOLE BARRIER

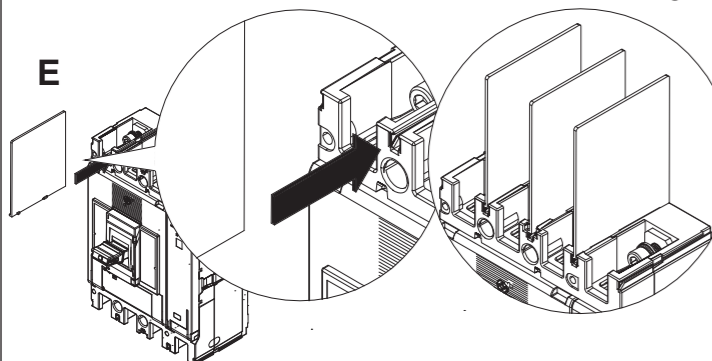

TERMINAL COVER LOCK

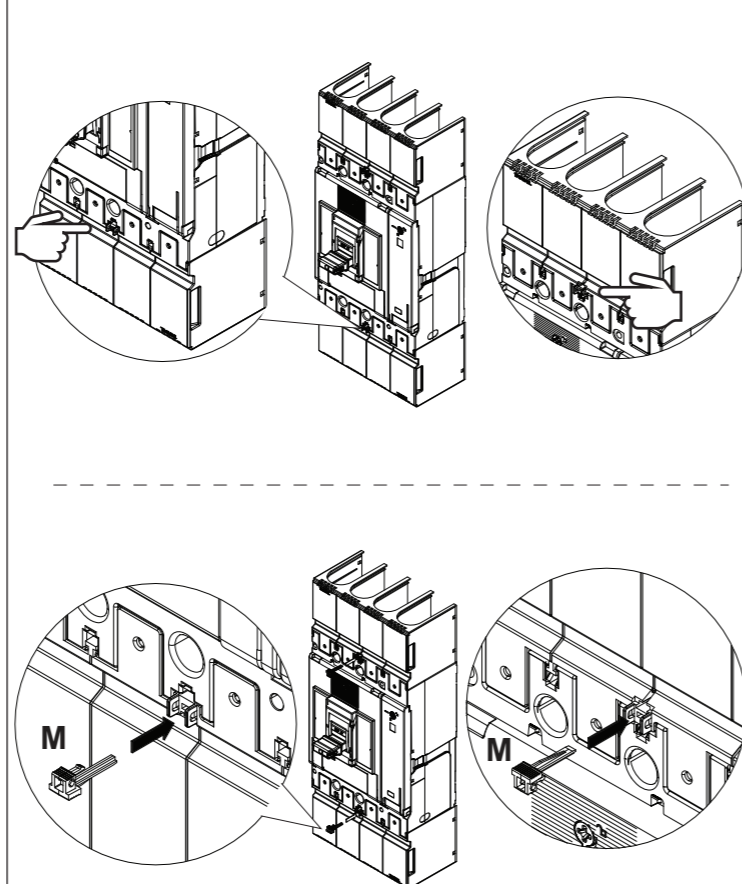

TOGGLE LOCK / PADLOCK ASSEMBLY PROCEDURE

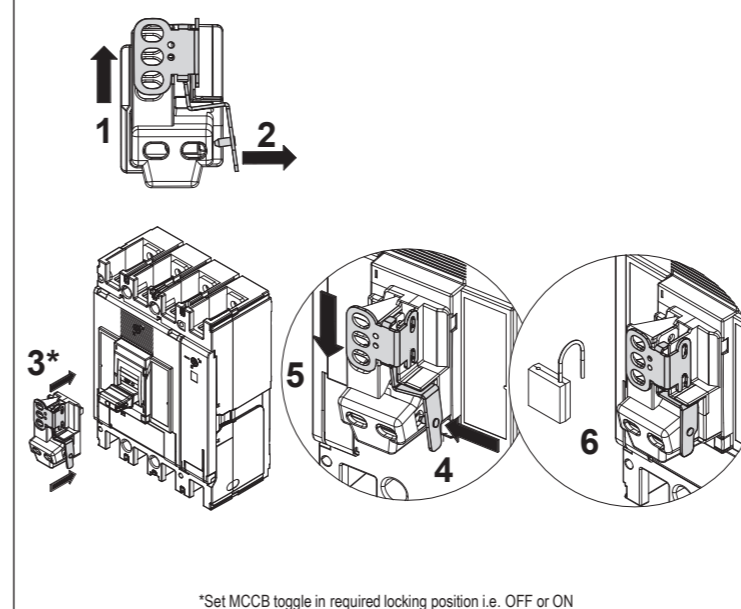

TOGGLE LOCK OPTION

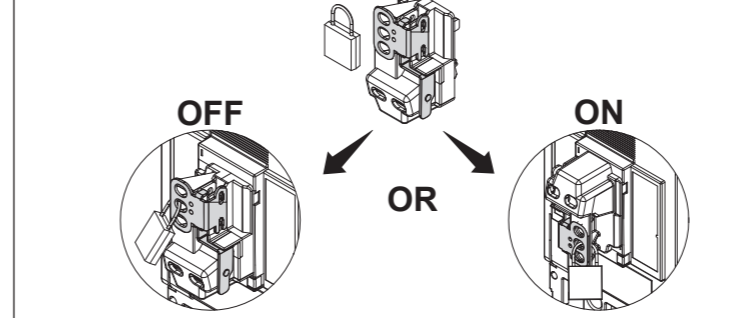

TIME CURRENT CHARACTERISTIC CURVE

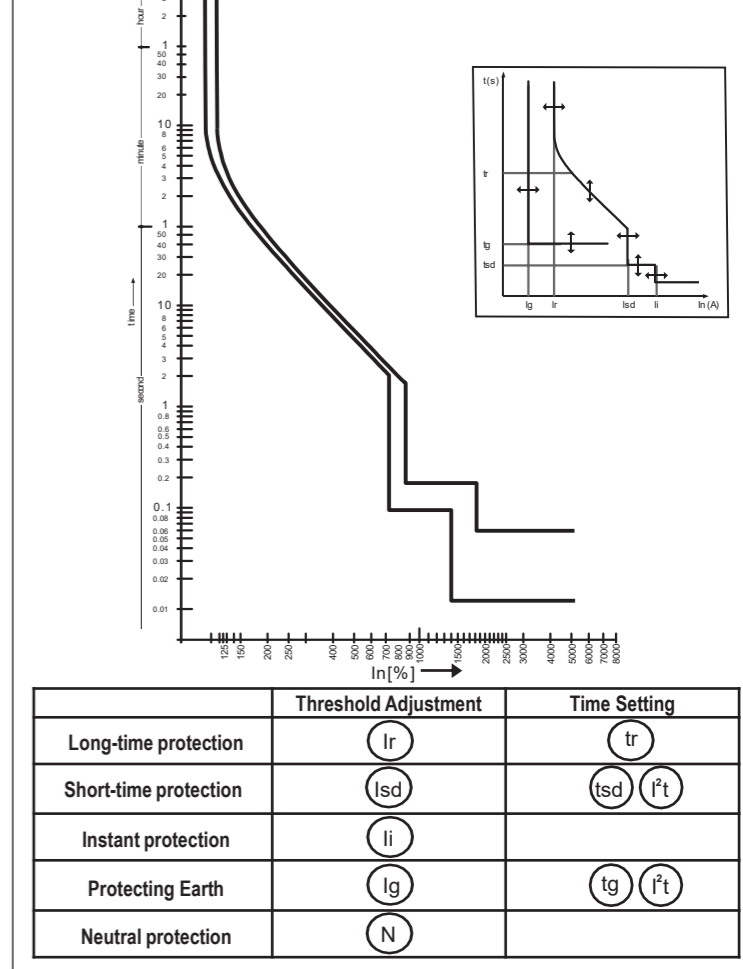

NOTE: The protection menu consists of sub-menus to view and edit each OCR protection setting