

# DF-2

## MEDIUM VOLTAGE SWITCHGEAR

THE MODULAR CONCEPT

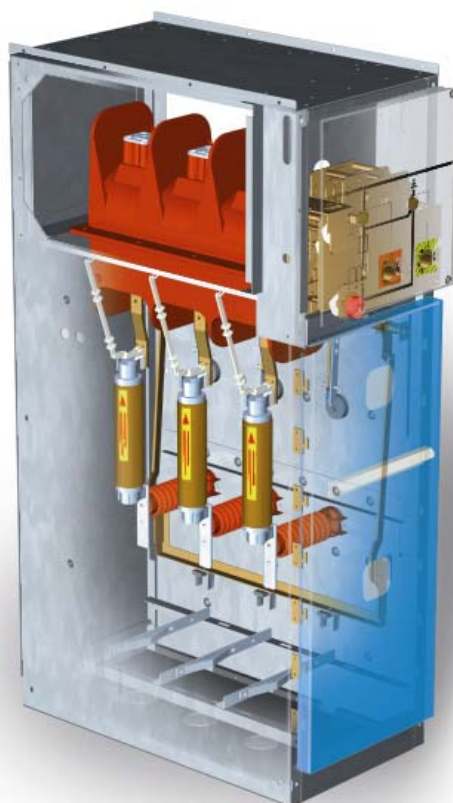

**User's manual**



THE SPECIALIST IN **MEDIUM VOLTAGE SWITCHGEAR**

**SwitchGear Company nv - Moorstraat 24 - B-9850 Nevele**

Tel: +32 (0)9/321.91.12 - Fax: +32 (0)9/321.91.13 - e-mail: [info@switchgearcompany.be](mailto:info@switchgearcompany.be) - [www.switchgearcompany.be](http://www.switchgearcompany.be)

© 2011 SwitchGear Company nv.

All rights reserved.

The information provided may not be reproduced and/or published in any way and by any means (electronic or mechanical), without the prior, explicit written authorisation of SwitchGear Company nv

The information provided is based on general data concerning the construction known at the time of publication, material qualities and working methods, so that the right to make changes is reserved.

The information given is applicable to the standard version of the DF-2 Medium Voltage Switchgear. Therefore SwitchGear Company nv. cannot be held liable for any damage resulting from specifications that differ from the standard version of the DF-2 Medium Voltage Switchgear.

The available information has been assembled with the greatest possible care but SwitchGear Company nv. cannot be held liable for any mistakes in the information or the consequences thereof.

The user names, trade names, trade marks, etc, used by SwitchGear Company nv. in accordance with the legislation concerning the protection of trademarks cannot be considered to be free.

# CONTENTS

<b>Contents.....</b>	<b>iii</b>
<b>Preface .....</b>	<b>viii</b>
This document .....	viii
Pictograms and safety symbols in and on the medium voltage switchgear.....	viii
Pictograms in the documentation .....	viii
Related documentation .....	ix
Service and technical support.....	x
Identification of the cubicles.....	x
General safety directions and instructions .....	xi
Intended use .....	xii
<b>1 General description .....</b>	<b>1-1</b>
1.1 DF-2, the modular concept .....	1-1
1.2 Compartmenting .....	1-2
1.2.1 Bus bar compartment .....	1-3
1.2.2 Apparatus compartment .....	1-3
1.2.2.1 Load break switch.....	1-3
1.2.3 Cable compartment .....	1-3
1.2.3.1 Earthing switch .....	1-3
1.2.3.2 Fuse switch combination .....	1-4
1.2.3.3 Circuit breaker .....	1-4
1.2.3.4 Provisions for the fixing of the feeding cables .....	1-4
1.2.4 Mechanical drive and low voltage compartment.....	1-5
1.2.4.1 Synoptic diagram .....	1-5
1.2.4.2 Drive mechanism.....	1-6
1.2.4.2.1 Combination load break switch – earthing switch.....	1-6
1.2.4.2.2 Combination load break switch – fuses .....	1-6
1.2.4.3 Options and accessories .....	1-6
1.2.5 Cable cubicle .....	1-7
1.2.6 Transformer cubicle .....	1-7
1.2.7 Measuring cubicle.....	1-7
1.2.8 The various DF-2 cubicles .....	1-7
1.2.8.1 Standard equipment per cubicle .....	1-7
1.2.8.2 Short description.....	1-8
<b>2 Technical specifications .....</b>	<b>2-1</b>
2.1 Electrical specifications.....	2-1
2.2 Dimensions and weights.....	2-2
2.2.1 DF-A cubicle .....	2-2
2.2.2 DF-P cubicle .....	2-2
2.2.3 DF-D cubicle .....	2-2
2.2.4 DF-D-W cubicle .....	2-2
2.2.5 DF-EDN-D cubicle .....	2-2
2.2.6 DF-EDN-LK cubicle .....	2-2
2.2.7 DF-AAD cubicle .....	2-3
2.2.8 DF-LK cubicle .....	2-3
2.2.9 DF-K cubicle .....	2-3
2.2.10 DF-T cubicle .....	2-4
2.2.11 DF-C cubicle .....	2-4
<b>3 Transport and storage.....</b>	<b>3-1</b>
3.1 Safety instructions – transport .....	3-1

3.2	Safety instructions – storage .....	3-1
<b>4</b>	<b>Installation.....</b>	<b>4-1</b>
4.1	Safety instructions – installation .....	4-1
4.1.1	General .....	4-1
4.1.2	Recommendations – installation area.....	4-1
4.1.2.1	Floor surface.....	4-1
4.1.2.2	Surrounding conditions .....	4-1
4.1.2.3	Ventilation .....	4-2
4.1.2.4	Free height of the installation area .....	4-2
4.1.2.5	The sizes of the entrance doors of the installation area .....	4-3
4.1.2.6	Free passage in front of the cubicles .....	4-3
4.1.2.7	Internal arc protection .....	4-3
4.2	Unpacking.....	4-4
4.3	Erection.....	4-5
4.4	Cubicle assembly.....	4-7
4.4.1	Connecting the cubicles.....	4-7
4.4.1.1	Kit as described hereunder.....	4-7
4.4.1.2	Preparation .....	4-7
4.4.1.3	Assembly procedures .....	4-8
4.4.2	Assembly of the earthing copper connection pieces .....	4-9
4.4.2.1	Kit as described hereunder.....	4-9
4.4.2.2	Preparation .....	4-9
4.4.2.3	Assembly procedures .....	4-9
4.4.3	Fitting the bus bars .....	4-10
4.4.3.1	Medium voltage switchgear 800 A – available kits for bus bars .....	4-10
4.4.3.1.1	Kit DS178001 as described hereunder.....	4-10
4.4.3.1.2	Kit DS178003 as described hereunder.....	4-11
4.4.3.1.3	Kit DS178002 as described hereunder.....	4-11
4.4.3.1.4	Kit DS178004 as described hereunder.....	4-12
4.4.3.1.5	Kit DS178005 as described hereunder.....	4-12
4.4.3.1.6	Kit DS178006 as described hereunder.....	4-13
4.4.3.2	Medium voltage switchgear 1,250 A - available kits for bus bars .....	4-13
4.4.3.2.1	Kit DS178011.....	4-13
4.4.3.2.2	Kit DS178012.....	4-14
4.4.3.2.3	Kit DS178013.....	4-14
4.4.3.2.4	Kit DS178014.....	4-15
4.4.3.2.5	Kit DS178015.....	4-15
4.4.3.2.6	Kit DS178016.....	4-16
4.4.3.3	Medium voltage switchgear (800 A) composed of two cubicles .....	4-17
4.4.3.3.1	Preparation .....	4-17
4.4.3.3.2	Assembly procedures .....	4-17
4.4.3.4	Medium voltage switchgear (800 A) composed of three (or a different uneven number of) cubicles .....	4-18
4.4.3.4.1	Preparation .....	4-18
4.4.3.4.2	Assembly procedures .....	4-18
4.4.3.5	Medium voltage switchgear (800 A) composed by four (or a different even number of) cubicles .....	4-19
4.4.3.5.1	Preparation .....	4-19
4.4.3.5.2	Assembly procedures .....	4-20
4.4.3.6	Medium voltage switchgear (1,250 A) composed of two cubicles .....	4-21
4.4.3.6.1	Preparation .....	4-21
4.4.3.6.2	Assembly procedures .....	4-21
4.4.3.7	Medium voltage switchgear (1,250 A) composed of three (or another odd number of) cubicles .....	4-22

4.4.3.7.1	Preparation .....	4-22
4.4.3.7.2	Assembly procedures .....	4-23
4.4.3.8	Medium voltage switchgear (1,250 A) composed by four (or another even number of) cubicles .....	4-24
4.4.3.8.1	Preparation .....	4-24
4.4.3.8.2	Assembly procedures .....	4-24
4.4.4	Assembly of the end panels.....	4-25
4.4.4.1	Kit DF117500 as described hereunder .....	4-25
4.4.4.2	Preparation .....	4-26
4.4.4.3	Assembly procedures .....	4-26
4.5	Greasing the earthing switch, the earthing knife spoons and the damping blocks.....	4-27
4.6	Fitting the front panels .....	4-28
4.7	Assembly of the floor pans .....	4-28
4.7.1	Kit DS178007.....	4-28
4.7.2	Preparation .....	4-29
4.7.3	Assembly procedures .....	4-29
4.8	Refitting the door .....	4-30
4.9	Measuring the phase sequence.....	4-31
4.10	Initial commissioning.....	4-31
<b>5</b>	<b>Use .....</b>	<b>5-1</b>
5.1	Safety instructions – use.....	5-1
5.2	Operation .....	5-1
5.2.1	Operating the combination load break switch earthing switch.....	5-2
5.2.1.1	Opening the load break switch and closing the earthing switch .....	5-2
5.2.1.2	Opening the earthing switch and closing the load break switch .....	5-3
5.2.2	Reading the capacitive voltage indicators .....	5-3
5.2.3	Operation of the double load break switch .....	5-3
5.2.3.1	Operation of the double load break switch .....	5-3
5.2.3.2	Closing the double load break switch .....	5-4
5.2.4	Operation of the combination load break switch – fuse .....	5-4
5.2.4.1	Opening the load break switch and closing the earthing switch .....	5-5
5.2.4.2	Opening the earthing switch and closing the load break switch .....	5-5
5.2.5	Operating the circuit breaker and the relay.....	5-6
5.2.6	Operating the low voltage switch .....	5-6
<b>6</b>	<b>Maintenance .....</b>	<b>6-1</b>
6.1	Safety instructions – maintenance.....	6-1
6.2	Maintenance - general.....	6-1
6.2.1	General checking actions .....	6-2
6.2.2	Cleaning the DF-2 cubicles.....	6-2
6.2.2.1	Cleaning the outside .....	6-2
6.2.2.2	Cleaning the inside .....	6-2
6.2.2.2.1	Sliding in and out the fix mounted circuit breaker (DF-D).....	6-3
6.2.2.2.2	Sliding in and out the withdrawable circuit breaker (DF-D-W).....	6-4
6.2.3	Lubricating the earthing knife and the damping blocks (if present) .....	6-5
6.2.4	Switching of the switch(es) (DF-2 cubicles with an interruption function).....	6-6
6.2.5	Replacing the fuse (DF-P cubicles) .....	6-6
6.2.6	Emptying the oil tray (DF-T cubicles with oil-filled transformers).....	6-7
<b>7</b>	<b>Connection diagrams .....</b>	<b>7-1</b>
7.1	Numbering of terminals DF-A, DF-P en DF-D: part 1 .....	7-1
7.2	Numbering of terminals DF-A, DF-P en DF-D: part 2 .....	7-2
7.3	Numbering of terminals DF-P: part 3 .....	7-3
7.4	Numbering of terminals DF-D: part 3.....	7-4
7.5	Numbering of terminals DF-A with motor Sibelgaz.....	7-5

7.6	Numbering of terminals CT / VT .....	7-6
7.7	Numbering of terminals DF-T: .....	7-7
7.8	Numbering of terminals general.....	7-8
<b>8</b>	<b>DF-2 cubicles and the environment.....</b>	<b>8-1</b>
8.1	Packing material .....	8-1
8.2	Disposal of the cubicles .....	8-1
<b>9</b>	<b>Mounting of options.....</b>	<b>9-1</b>
9.1	Auxiliary contacts.....	9-2
9.1.1	Preparation for mounting .....	9-2
9.1.2	Mounting of auxiliary contacts - general .....	9-2
9.1.3	Final checking and commissioning .....	9-3
9.1.4	Mounting of auxiliary contacts – specific (for each drive mechanism).....	9-3
9.1.4.1	DP – Auxiliary contact(s) on the load break switch.....	9-3
9.1.4.1.1	Available auxiliary contacts.....	9-4
9.1.4.1.2	Mounting instructions.....	9-4
9.1.4.2	DA-K – Auxiliary contact(s) on the load break switch .....	9-5
9.1.4.2.1	Available auxiliary contacts.....	9-6
9.1.4.2.2	Mounting instructions.....	9-6
9.1.4.3	DA-K-M – Auxiliary contact(s) on the load break switch .....	9-7
9.1.4.3.1	Available auxiliary contacts.....	9-8
9.1.4.3.2	Mounting instructions.....	9-8
9.1.4.4	DA-EDN-D – Auxiliary contact(s) on the load break switch .....	9-9
9.1.4.4.1	Available auxiliary contacts.....	9-10
9.1.4.4.2	Mounting instructions.....	9-10
9.1.4.5	DA-M – Auxiliary contacts for the key lock on the load break switch/earth switch.....	9-11
9.1.4.5.1	Available auxiliary contacts.....	9-12
9.1.4.5.2	Mounting instructions.....	9-12
9.1.4.6	DA – Auxiliary contact(s) on the load break switch/earth switch .....	9-13
9.1.4.6.1	Available auxiliary contacts.....	9-14
9.1.4.6.2	Mounting instructions.....	9-15
9.1.4.7	DA-M – Auxiliary contacts on the earth switch .....	9-16
9.1.4.7.1	Available auxiliary contacts.....	9-16
9.1.4.7.2	Mounting instructions.....	9-17
9.1.4.8	DP – Auxiliary contact for indicating the status of fuses .....	9-18
9.1.4.8.1	Mounting instructions.....	9-18
9.1.4.9	DP-M – Auxiliary contact for indicating the status of fuses.....	9-20
9.1.4.9.1	Mounting instructions.....	9-21
9.2	Key locks .....	9-22
9.2.1	Preparation for mounting .....	9-22
9.2.2	Mounting of key locks - general .....	9-23
9.2.3	Final checking and commissioning .....	9-24
9.2.4	Mounting of key locks – specific (for each drive mechanism).....	9-24
9.2.4.1	DP – Key locks on the earth switch .....	9-24
9.2.4.1.1	Mounting instructions.....	9-24
9.2.4.2	DP – Key lock on the load break switch .....	9-26
9.2.4.2.1	Mounting instructions.....	9-27
9.2.4.3	DA-M – Key locks on the load break switch/earth switch .....	9-28
9.2.4.3.1	Mounting instructions.....	9-28
9.3	Shunt-trip releases.....	9-29
9.3.1	Preparation for mounting .....	9-29
9.3.2	Mounting of shunt-trip releases - general .....	9-30
9.3.3	Final checking and commissioning .....	9-30
9.3.4	Mounting of shunt-trip releases – specific (for each drive mechanism).....	9-30
9.3.4.1	DP, DP-M, DP-A, DP-A-M – Shunt-trip release on the load break switch .....	9-30

9.3.4.1.1	Available release types.....	9-30
9.3.4.1.2	Mounting instructions.....	9-31
9.3.4.1.3	Electrical monitoring with external power source.....	9-33
9.4	Under-voltage releases.....	9-33
9.4.1	Preparation for mounting .....	9-33
9.4.2	Mounting of under-voltage releases - general .....	9-34
9.4.3	Final checking and commissioning .....	9-34
9.4.4	Mounting of under-voltage releases – specific (for each drive mechanism).....	9-34
9.4.4.1	DP, DP-M, DP-A, DP-A-M – Under-voltage release delayed with minutia on the load break switch.....	9-34
9.4.4.1.1	Available release types.....	9-34
9.4.4.1.2	Mounting instructions.....	9-35

## PREFACE

### This document

This document is intended as a reference with which qualified and trained operators can transport, install, use and maintain the medium voltage switchgear in a safe and economic way.

In this document the definition “medium voltage switchgear” is used to indicate a random – but occurring in practice – combination of DF2 cubicles that, connected, form a customer-specific transformation or distribution switchgear. For details, see “General description”.

The chapters and sections are numbered. The page numbering (consisting of the chapter number and the page number) and the document code can be found at the bottom of each page.

In the documentation the words “left”, “right”, “front” and “behind” are used to indicate a specific part of the medium voltage switchgear. The starting point for this is always the position of the operator, standing at the front side of the switchgear.

### Pictograms and safety symbols in and on the medium voltage switchgear

Depending on the version, the following pictogram is used on the medium voltage switchgear:



#### **WARNING**

Danger of high voltage

Access to the particular cubicle is only allowed after the cubicle itself, the directly following and the previous cubicle are voltage free.

### Pictograms in the documentation

In the user’s manual of the medium voltage switchgear, the following pictograms are used:



#### **CAUTION**

Procedures that can – when not carried out with the necessary care - result in damage to the medium voltage switchgear, the surrounding area or the environment.



#### **WARNING**

Danger of high voltage





**CAUTION**  
Entrapment danger



Notes, suggestions and advices

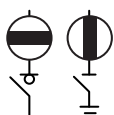

Make the cubicle in question, the immediately following one and the previous cubicle voltage free, before carrying out the work described.

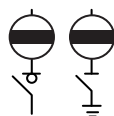

Open the load break switch as well as the earthing switch before carrying out the work described.



Consult the indicated information sources first.



Protect the medium voltage switchgear from water or damp.

## Related documentation

The following technical documentation is available for the medium voltage switchgear:

- Spare-parts list (AG608301)
- Technical brochure (AG601301)

## Service and technical support

For information concerning specific settings, maintenance or repair work that is not mentioned here, please contact SwitchGear Company nv.

- In this case, always mention the following data:
  - cubicle type and voltage
  - serial number of the cubicle(s)
  
- See “Identification of the cubicles”.

## Identification of the cubicles

Each cubicle of the medium voltage switchgear is fitted with an identification plate (fig. 0.01) and a stamped serial number (fig. 0.02).

### Identification plate

- See fig. 0.01:

A cubicle type  
 B voltage  
 C other technical specifications

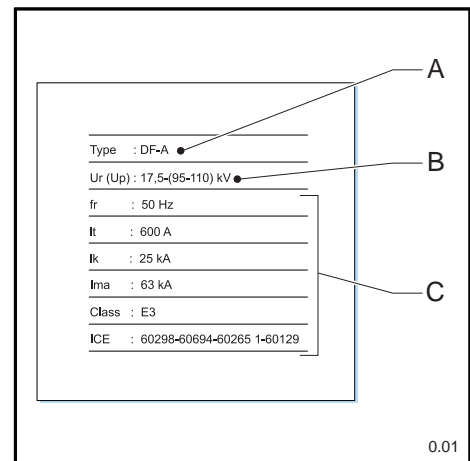

### Serial number

As standard, the stamped serial number (fig. 0.02A) is on the front of the sidewall or on the horizontal wall, level with the front panel (fig. 0.02B). The serial number is visible after removing the front panel. See “Erection”.

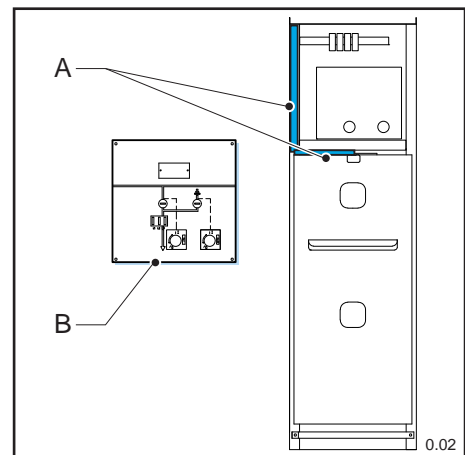

## **General safety directions and instructions**

SwitchGear Company nv does not accept any liability for damage or injury caused by not (strictly) following the safety directions and instructions, or by negligence during the installation,

the use, the maintenance or the repair of the medium voltage switchgear and any accompanying options.

Depending on the specific user circumstances or options fitted, extra safety instructions may be necessary. Please contact SwitchGear Company nv immediately if you encounter a potential danger when using the medium voltage switchgear.

**The owner/operator of the medium voltage switchgear is fully responsible at all times for following the locally applicable safety directions and guidelines.**

### **User's manual**

- Anyone who uses or operates the medium voltage switchgear, must know the contents of the user's manual and follow the directions contained in it very closely. The owner/operator must teach the users in accordance with the user's manual and obey all directions and instructions.
- Never change the order of the actions to be taken.
- Always keep the user's manual in the vicinity of the medium voltage switchgear.

### **Pictograms and safety symbols**

Pictograms, symbols and instructions fitted to the medium voltage switchgear are a part of the safety equipment. They may not therefore be covered or removed and must be present and clearly readable throughout the entire lifetime of the medium voltage switchgear.

- Replace or repair unreadable or damaged pictograms, symbols and instructions immediately. Therefore, contact SwitchGear Company nv.

### **Operators**

The performance of the work described (transport, installation, use and maintenance) is strictly reserved for operators trained and qualified to do so who are familiar with the dangers that can occur when using medium voltage switchgears. Temporary staff and personnel in training may not operate the medium voltage switchgear in any way.

### **Technical specifications**

- The technical specifications may not be changed.
- Modification of (parts of) the medium voltage switchgear is not permitted.

## Transport, storage, installation, use and maintenance

- See:
  - “Safety instructions – transport”
  - “Safety instructions – storage”
  - “Safety instructions – installation”
  - “Safety instructions – use”
  - “Safety instructions – maintenance”

## Intended use

The medium voltage switchgear is exclusively designed to be used as transformation or distribution switchgear, in accordance with the specifications and conditions provided by SwitchGear Company nv. Any other or further use is not in conformity with the purpose<sup>1</sup>. SwitchGear Company nv accepts no liability for any damage or injury resulting from this.

The medium voltage switchgear is in accordance with the applicable standards and guidelines. See the Technical Brochure (order number: AG601301).

- Only use the medium voltage switchgear in technically perfect condition, in accordance with the intended use described above.



Always keep sealed connections intact at all times. Breaking the sealed connections irrevocably voids any claims under guarantee.

---

<sup>1</sup>"Intended use" as laid down in EN 292-1 is the use for which the technical product is suited as specified by the manufacturer-including his directions in the sales brochure. In case of doubt it is the use that can be deduced from the construction, the model and the function of the technical product that is considered normal use. Operating the product within the limits of its intended use also involves observing the instructions in the user manual.

# 1 GENERAL DESCRIPTION

## 1.1 DF-2, the modular concept

The DF-2 concept of SwitchGear Company nv offers the capability to custom assemble any required transformation or distribution switchgear in a rational and economic way, by using a number of functional basic modules: the DF-2 cubicles.

By combining these basic modules (and their options) in the correct manner, a customer-specific medium voltage switchgear is created (with a nominal voltage of 12, 17.5 or 24 kV) that offers a high level of operator safety.

The technical specifications of your medium voltage switchgear can be found on the name plates on the cubicles. See “Identification of the cubicles”.

The modularity of the DF-2 concept is not limited to the ability to build various configurations with the DF-2 cubicles. Each DF-2 cubicle on its own is also a assembly of modules that – built into the compartments created for this purpose - determine the function of the particular cubicle. See “Compartmenting”.

## 1.2 Compartmenting

DF-2 cubicles **with an interrupting function** (DF-A, DF-P, DF-D, DF-D-W, DF-EDN-D, DF-EDN-LK, DF-AAD and DF-LK) consists in an assembly of four compartments. The arrangement of these compartments determines the functioning of the cubicle.

- See:
  - “Bus bar compartment” (fig. 1.01D)
  - “Apparatus compartment” (fig. 1.01C)
  - “Cable compartment” (fig. 1.01B)
  - “Mechanical drive and low voltage compartment” (fig. 1.01A)

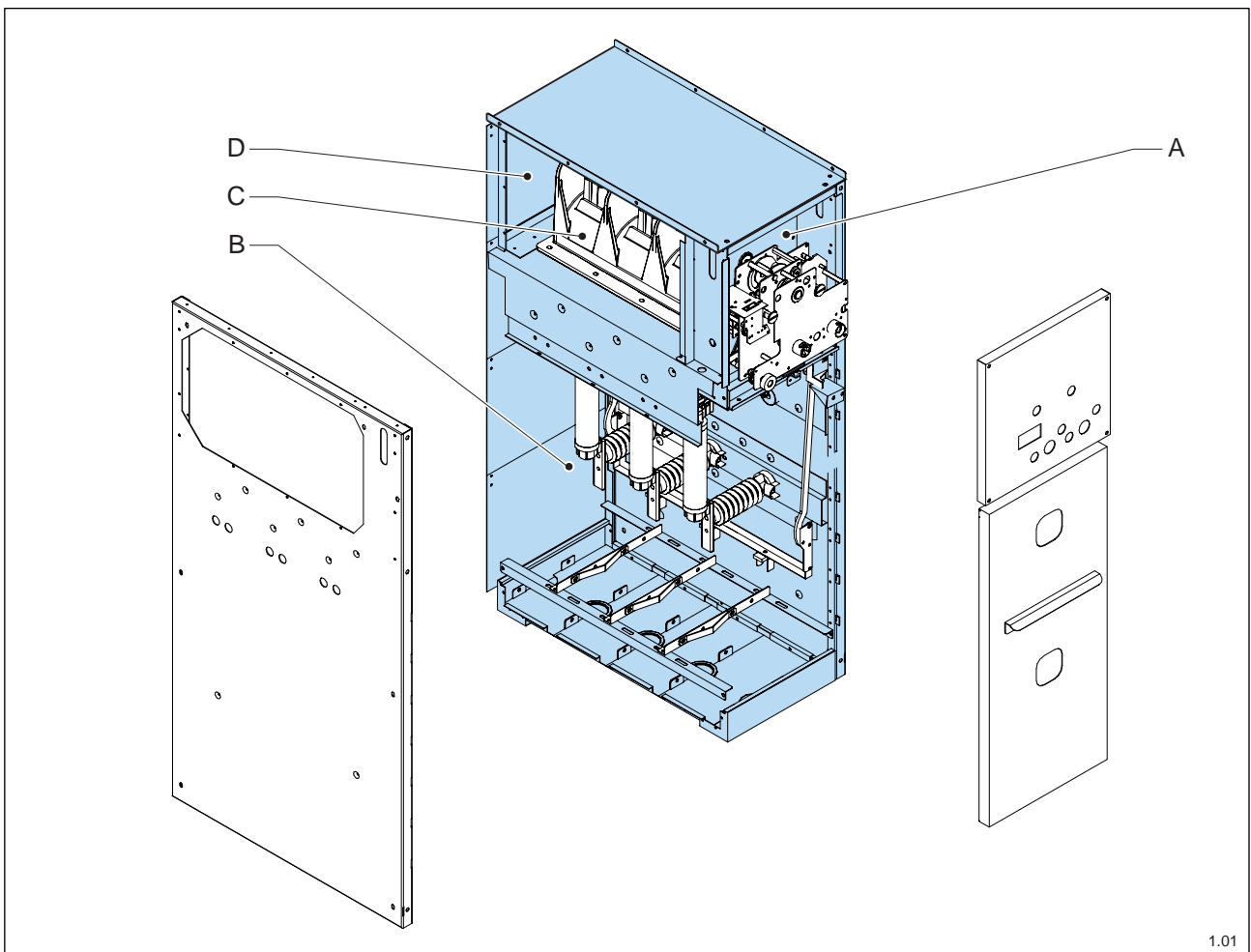

DF-2 cubicles **without interrupting function** (DF-K, DF-T and DF-C) have less modularity. These cubicles distinguish themselves by the presence of:

- provisions for feeding in the supply cables
- provisions for current and voltage transformers
- provisions to allow measurements (of energy consumption) and/or controls

- See:
  - “Cable cubicle”
  - “Transformer cubicle”
  - “Measuring cubicle”

### **1.2.1 Bus bar compartment**

The bus bar compartment is behind the mechanical drive and low voltage compartment. The various cubicles of the medium voltage switchgear are electrically connected by means of a bus bar. The modular bus bar consists of three bars, made from electrolytic copper F25, which should be fitted when the medium voltage switchgear is installed. See “Fitting the bus bars”.

### **1.2.2 Apparatus compartment**

The equipment compartment is between the bus bar compartment and the cable compartment. Depending on the version, this compartment contains one or two load break switches.

#### **1.2.2.1 Load break switch**

The RV 44 load break switch forms the physical segregation between the bus bar compartment and the cable compartment.

The load break switch is filled with SF<sub>6</sub> gas (sulphur hexafluoride) and sealed for life. The special characteristics of the SF<sub>6</sub> gas in the casing fulfil an isolating as well as an arc extinguishing function.

The load break switch is a two-position switch that connects or interrupts the electrical voltage between the high voltage cables and the bus bar. The position of the load break switch is clearly indicated in the synoptic diagram. Depending on the version, the load break switch is operated manually or electrically. See “Drive mechanism”.

### **1.2.3 Cable compartment**

The cable compartment is behind the lockable, removable door. Depending on the version, this compartment contains one or more of the following items:

- EM 20 earthing switch
- Fuse switch combination
- Circuit breaker
- Provisions for securing the supply cable(s)

#### **1.2.3.1 Earthing switch**

The EM 20 earthing switch is located underneath the RV 44 load break switch, on the right wall of the cubicle. The switching is done in air (in contrast to that of the load break switch).

The earthing switch is a two-position switch that opens the earthing knife (no earthing) or closes it (visible earthing). The position of the earthing switch is clearly indicated on the synoptic diagram.

Depending on the version, the load break switch is operated manually or electrically. The earthing switch is housed with the load break switch in one, mechanically interlocked drive mechanism. See “Drive mechanism”.

### **1.2.3.2 Fuse switch combination**

The fuse switch combination is a protecting device consisting of:

- A RV 44 load break switch (see “Load break switch”)
- An EM 20 earthing switch (see “Earthing switch”)
- Fuse holders
- A second earthing switch (auxiliary earthing switch) for eventual dispersing of residual currents

With a fuse switch combination, both earthing switches are mechanically interconnected allowing a simultaneously opening or closing.

### **1.2.3.3 Circuit breaker**

The circuit breaker is protecting the output feeders, transformers and motors. Depending on the version, the circuit breaker is of the fixed type (but easily removable) or of the withdrawable type.

### **1.2.3.4 Provisions for the fixing of the feeding cables**

Thanks to the following provisions the feeding cables can be connected on a quickly and simply manner:

- Removable floor pans with grommets
- Fixed cable supports
- In depth adjustable cable supports



The connections fitted to your medium voltage switchgear have been adjusted to the specific operating voltage.



## 1.2.4 Mechanical drive and low voltage compartment

The mechanical drive and low voltage compartment is located behind the removable front panel. Depending on the version, this compartment contains one or more of the following items:

- Synoptic diagram (on the front panel) showing the position of the switch(es) and any other indication and operating devices
- Drive mechanism
- Options and accessories (like auxiliary contacts, opening and closing coils, key interlocks, under voltage release, motor operating devices, etc. and the necessary electrical connectors)

### 1.2.4.1 Synoptic diagram

The synoptic diagram (fig. 1.02) on the front panel indicates on a single line diagram the power flow and the various positions of the components of the concerned cubicle.

Fig. 1.02 shows –by means of an example- the synoptic diagram of a standard DF-P cubicle:

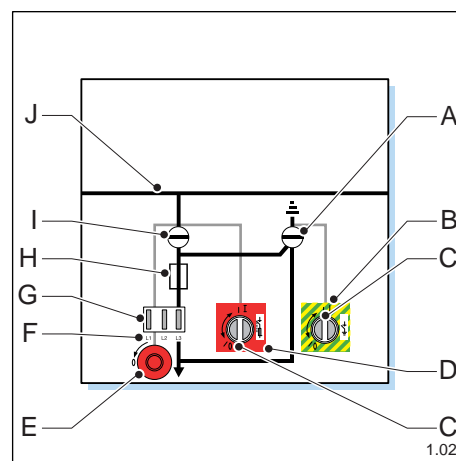

Colour codes may vary from country to country. The supplied medium voltage switchgear however is fitted with the colour codes that are valid in your country.

- A Earthing switch' (open / closed) position indicator.
- B Operating device of the earthing switch  
The arrow on the operating device indicates the mandatory direction of rotation for the opening (O) and the closing (I) of the earthing switch.
- C Slot for fitting the operating handle
- D Operating device of the load break switch  
The arrow on the operating device indicates the mandatory rotation direction for closing (I) the load break switch.
- E Load break switch opening button (O).
- F Voltage indication
- G Connectors for voltage indicators
- H Graphic representation of the fuses
- I 'Load break switch position' indicator (open / closed)
- J Single line diagram

#### 1.2.4.2 Drive mechanism

DF-2 cubicles **with an interrupting function** are fitted with a drive mechanism for the operation of the switch(es). The drive mechanism is located behind the front panel.

The nine different types of drive mechanisms can be reduced to two major models.

- See:
  - “Combination load break switch – earthing switch”
  - “Combination load break switch – fuse safety”

##### 1.2.4.2.1 Combination load break switch – earthing switch

Depending on the version, the load break switch and/or the earthing switch are operated manually or electrically. Manual operation is done with the operating handle supplied. The opening and closing device of the load break switch and the earthing switch have been fitted in one drive mechanism. Both switches have their own, separate operating shaft. The operating shafts are mechanically interlocked to prevent wrong switching operations.

##### 1.2.4.2.2 Combination load break switch – fuses

Depending on the version, the load break switch and/or the earthing switch are operated manually or electrically. Manual operation is done with the operating handle supplied. The opening and closing device of the load break switch and the earthing switch have been fitted in one drive mechanism. Both switches have their own, separate operating shaft. The operating shafts are mechanically interconnected to prevent wrong switching operations. Hitting bolts connected to a shaft on the top of the fuse ensures that the load break switch opens, in case of fuse blowing.

#### 1.2.4.3 Options and accessories



Various options can be supplied for each cubicle type.  
See “Assembly of options”.

### 1.2.5 Cable cubicle

The cable cubicle is a cubicle allowing the connection of the feeding cables. Depending on the version, cubicle is fitted with a bus bar and used as the incoming cubicle of the medium voltage switchgear.

### 1.2.6 Transformer cubicle

The transformer cubicle makes it possible to install and connect distribution transformers.

### 1.2.7 Measuring cubicle

The measuring cubicle allows the installation of single, double or three-phase voltage and current transformers used for energy metering.

### 1.2.8 The various DF-2 cubicles

#### 1.2.8.1 Standard equipment per cubicle

The DF-2 cubicles differentiate themselves by their function. In the following table you will find the various cubicle types with the **standard equipment per cubicle** in the form of a cross-reference to the described cubicle function.

cubicle types with interrupting function								
	DF-A	DF-P	DF-D	DF-D-W	DF-EDN-D	DF-EDN-LK	DF-AAD	DF-LK
bus bar	X	X	X	X	X	X	X	X
load break switch	X	X	X	X	X	X	X	X
earthing switch	X	X	X	X	X	-	-	-
Load break /fuse combination	-	X	-	-	-	-	-	-
circuit breaker	-	-	X	X	X	-	X	-
cable fittings	X	X	X	X	X	-	-	-
synoptic diagram	X	X	X	X	X	X	X	X
drive mechanism	X	X	X	X	X	X	X	X
cable cubicle	X	X	X	X	X	-	-	-
transformer cubicle	-	-	-	-	-	-	-	-
measuring cubicle	-	X	X	-	X	-	-	-

<b>cubicle types without interrupting function</b>			
	DF-K	DF-T	DF-C
bus bar	X	-	X
load break switch	-	-	-
earthing switch	-	-	-
Load break/fuse combination	X	-	-
circuit breaker	-	-	-
cable fittings	X	-	X
synoptic diagram	-	-	-
drive mechanism	X	-	-
cable cubicle	X	-	-
transformer cubicle	-	X	-
measuring cubicle	X	-	X

### 1.2.8.2 Short description

<b>cubicle types with interrupting function</b>	<b>description</b>
DF-A	Incoming cubicle with load break switch
DF-P	Transformer protection cubicle with load break switch – fuse combination
DF-D	Protection cubicle with load break switch and fixed mounted vacuum-circuit breaker
DF-D-W	Protection cubicle with load break switch and withdrawable vacuum-circuit breaker
DF-EDN-D	Protection cubicle with load break switch and fixed mounted vacuum-circuit breaker – Electrabel design
DF-EDN-LK	Bus bar coupling cubicle with double load break switch – Electrabel design
DF-AAD	Bus bar coupling cubicle with double load break switch and vacuum circuit breaker
DF-LK	linking Bus bar coupling cubicle

<b>cubicle types without interrupting function</b>	<b>description</b>
DF-K	Cable cubicle with bus bar and/or with cable fittings
DF-T	Transformer cubicle
DF-C	Measuring cubicle

The cubicles are equipped as standard with a pressure relief system protecting the operator against the consequences of (the unlikely event of) an internal arc or short circuit. See “Internal arc security device”.

## 2 TECHNICAL SPECIFICATIONS



The stated technical specifications concerned exclusively the standard version of cubicles.

### 2.1 Electrical specifications

- See following table.

Rated voltage	kV	12	17,5	24
Impulse withstand voltage 1.2 / 50 $\mu$ s				
To earth and between phases	kV	75	95	125
Over the insulating distance	kV	85	110	145
Power frequency withstand voltage 1 min.				
To earth and between phases	kV	28	38	50
Over the insulating distance	kV	32	45	60
Rated frequency	Hz	50/60	50/60	50/60
Rated voltage <sup>1</sup>	A	800/1250	800/1250	800/1250
Rated short circuit current current 1 s.	kA	25	25	20
Nominal Rated peak value of the current	kA	63	63	50
Breaking capacity RV 44 (IEC 60265.1)				
Rated current	A	800/1250	800/1250	630
Closed loop	A	800/1250	800/1250	630
Load cable charging	A	18	18	18
Making current	kA	63	63	50
Earth fault	A	100	100	100
Earth fault cable charging	A	30	30	30
Internal arc 1 s. (6 criteria)	kA	16	16	16
Degree of protection		IP4X		
Mechanical durability c/o		1000		
Standards		IEC 60298 Annex AA, IEC 60129, IEC 60420, IEC 60694, C 64-701 (only in Belgium), IEC 60265.1		
Certificates		KEMA		

<sup>1</sup> In line with IEC 60265.1, clas E1.

## 2.2 Dimensions and weights

### 2.2.1 DF-A cubicle

- See fig. 2.01.

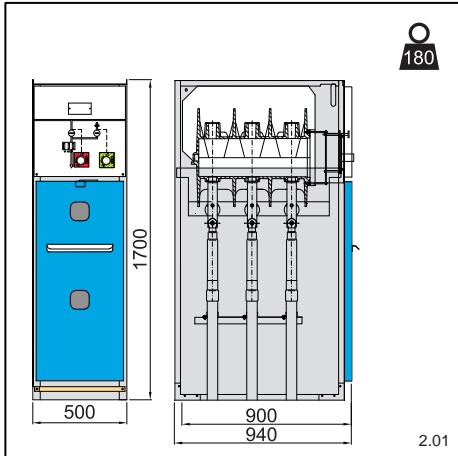

### 2.2.2 DF-P cubicle

- See fig. 2.02.

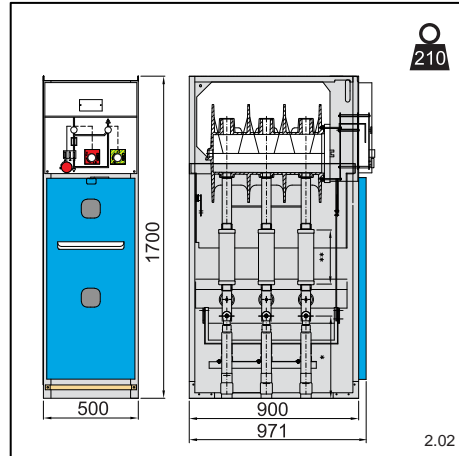

### 2.2.3 DF-D cubicle

- See fig. 2.03.

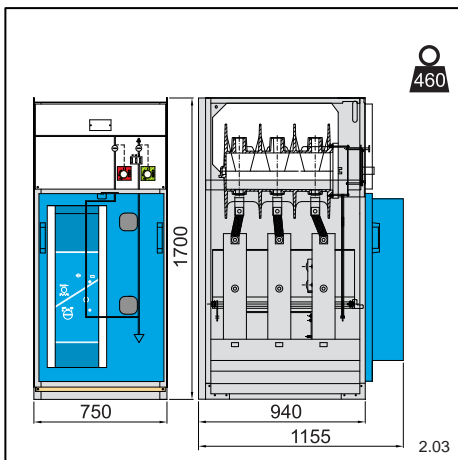

### 2.2.4 DF-D-W cubicle

- See fig. 2.04.

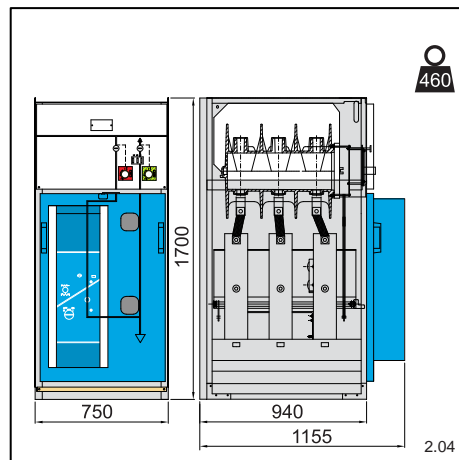

### 2.2.5 DF-EDN-D cubicle

- See fig. 2.05.

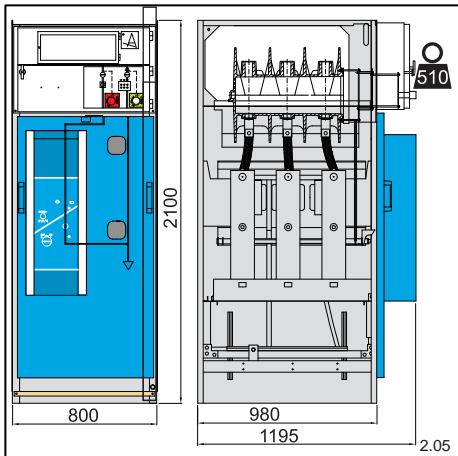

### 2.2.6 DF-EDN-LK cubicle

- See fig. 2.06.

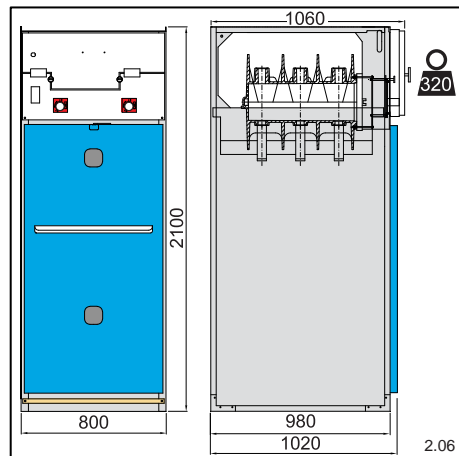

### 2.2.7 DF-AAD cubicle

- See fig. 2.07.

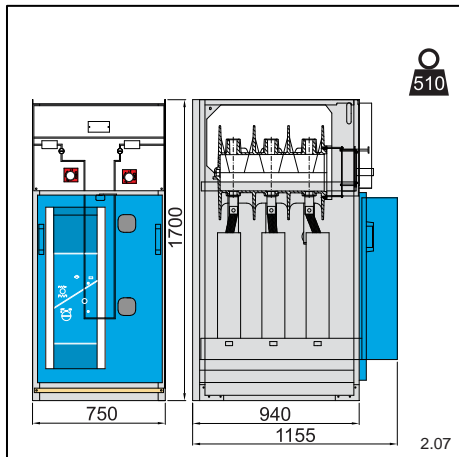

### 2.2.8 DF-LK cubicle

- See fig. 2.08.

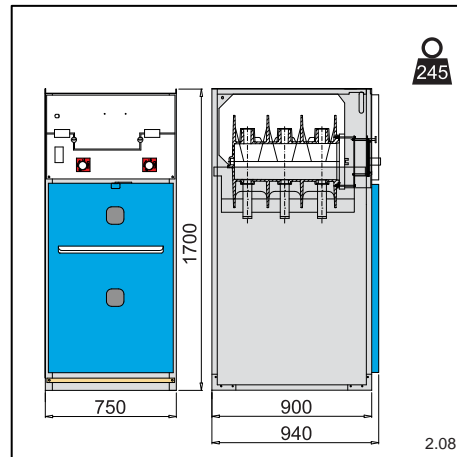

### 2.2.9 DF-K cubicle

- See fig. 2.09.

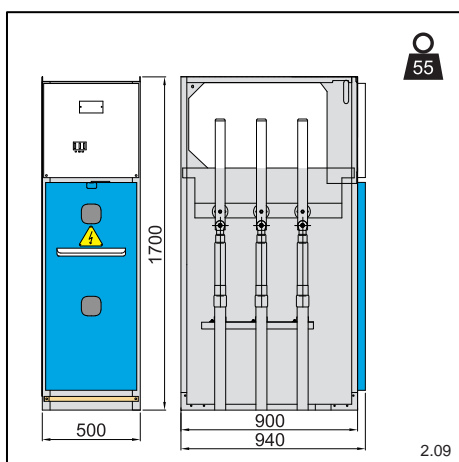

The given weight is for a cubicle without equipment

### 2.2.10 DF-T cubicle

- See fig. 2.10.

The dimensions of the DF-T cubicle can vary in function of following factors:

- Transformer power
- Type of transformer (oil filled or resin casted)
- Cable incoming and -outgoing
- Low-voltage equipment

The following table shows the standard dimensions of the DF-T cubicle.

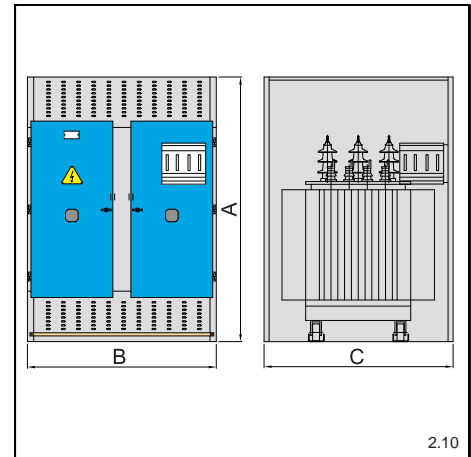

transformer power (in kVA)	cubicle sizes (in mm)					
	oil filled transformer			resin casted transformer		
	width Fig. 2.10B)	height Fig. 2.10A)	depth Fig. 2.10C)	width Fig. 2.10B)	height Fig. 2.10A)	depth Fig. 2.10C)
100 – 160	1.200	1.900	1.050	1.500	1.900	1.050
250 – 630	1.400	2.100	1.150	1.800	2.100	1.150
800 – 1.000	1.800	2.100	1.150	2.000	2.100	1.200
1.250 – 1.600	2.000	2.100	1.400	2.200	2.200	1.300
2.000 – 2.500	2.400	2.400	1.500	2.400	2.400	1.400

### 2.2.11 DF-C cubicle

- See fig. 2.11.

The given weight is for a cubicle without equipment.

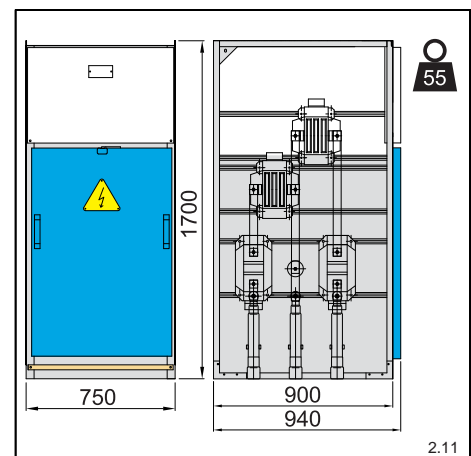



## 3 TRANSPORT AND STORAGE

### 3.1 Safety instructions – transport



Transportation of (the cubicles of) the medium voltage switchgear is restricted to qualified and trained operators while observing the locally applicable safety instructions and guidelines.

The cubicles can only be transported **internally**.

- Also see “General safety directions and instructions”.
- Before transporting the cubicles:
  - Ensure secure attachment of the cubicles to the forklift or hand trolley.
  - Check that all parts (especially the doors) are attached properly.
- Do not tilt the cubicles, but always transport them upright.
- Do not place other objects or tools on top of the cubicles to be transported.



Protect the cubicles from water or damp.



Cubicles that have fallen over during transport or have otherwise been seriously damaged must always be sent back for control to SwitchGear Company nv before putting the cubicles into operation.

### 3.2 Safety instructions – storage

- Also see “General safety directions and instructions”.
- Respect the surrounding conditions. See “Surrounding conditions”.
- Never stack cubicles on top of each other.
- Store the cubicles in a dry, dust free area.



## 4 INSTALLATION

### 4.1 Safety instructions – installation

#### 4.1.1 General



Installation of the medium voltage switchgear is restricted to qualified and trained operators with strictly observance of the locally applicable safety instructions and guidelines.

The connection and the putting into service must be done by qualified and authorised staff who are employed by the power supply company.

- Also see “General safety directions and instructions”.
- Never leave tools or other material in or on top of the medium voltage switchgear.
- Install the medium voltage switchgear only in areas that are fully in compliance with the following recommendations. (according to IEC 60298).

#### 4.1.2 Recommendations – installation area

The IEC recommendations concerning the installation area are divided into recommendations concerning:

- The floor surface
- The surrounding conditions
- The ventilation
- The free height of the installation area
- The sizes of the entrance doors in the installation area
- The free passage in front of the cubicles
- The internal arc protection

##### 4.1.2.1 Floor surface

The surface on which the medium voltage switchgear must be installed must be sufficiently strong and completely levelled. The maximum permissible difference in level is **2 mm/m**.

##### 4.1.2.2 Surrounding conditions

The DF-2 cubicles have been designed for **indoor installation** in the following surrounding conditions:

description	value
Surrounding temperature	Min. -15 °C - max. +45 °C
Relative air humidity	Min. 10% - max. 70% (without the formation of condensation)
installation altitude	Max. 1,000 m above sea level

This means that one has to :

- Avoid installation in dusty areas.
- Avoid installation in areas with high relative air humidity.
- Avoid installation in areas subject to lightning strikes.
- Avoid installation in surroundings where the cubicles can come into contact with aggressive gases or fluids.



Contact SwitchGear Company nv when cubicles must be installed in areas where the surrounding conditions cannot be guaranteed.

#### 4.1.2.3 Ventilation

- Ensure that there is good ventilation of the installation area.
- Protect the ventilation openings so that little animals or vermin do not have access to the installation area.

In particular, when the medium voltage switchgear contains one or more transformer cubicles, special attention should be given to the ventilation.

- Consult the following table when calculating the ventilation value.  
The table indicates the power losses of cast resin transformers.

transformer power (in KVA)	P to (W)
100	1,605
160	2,175
250	2,850
315	3,412
400	4,012
500	4,837
630	5,745
800	6,787
1,000	7,875
1,250	10,350
1,600	12,450
2,000	16,125

#### 4.1.2.4 Free height of the installation area

The free height of the installation area must be at least **2,200 mm**.

Local power supply companies may, however, require more free height. Always observe these requirements. An ideal, and generally accepted, value is 2,500 mm.



With dry type transformers with a capacity of = 1.250 KVA the free height must be at least **2,500 mm**.

#### 4.1.2.5 *The sizes of the entrance doors of the installation area*

The dimensions given apply for all doors accessing the installation area. These minimum door sizes therefore also apply when the installation area is not directly accessible from the outside.

description	value
Height of the entrance door	Min. 2,200 mm
Width of the entrance door	Min. 100 mm + width of the widest cubicle



If the medium voltage switchgear does not contain transformer cubicle(s), a minimum door height of **2,000 mm** will be sufficient.

If a transformer cubicle is included, refer to the transformer dimensions. For the correct dimensions of the various cubicles, see “Dimensions and weights”.

If the medium voltage switchgear must be installed in basements or storage basements, an entrance hatch must be supplied whose length as well as width is at least 400 mm larger than the dimensions of the largest cubicle or the transformer.

#### 4.1.2.6 *Free passage in front of the cubicles*

The free passage in front of the cubicles depends on the composition of the medium voltage switchgear.



If the medium voltage switchgear does not contain transformer cubicle(s), the minimum free passage is **1,500 mm** (preferably 2,500 mm).

With medium voltage switchgears with a transformer cubicle with a capacity of  $\geq 1.000$  KVA the free passage must have a minimum of **2,000 mm**.

#### 4.1.2.7 *Internal arc protection*

To prevent major material damage and serious physical injury or electrocution in the (unlikely) event of an internal arc, the following installation instructions apply:

- Leave at least **150 mm** free between the rear wall of the cubicles and the wall of the installation area. In this way the back plate over pressure system can operate if (unlikely) an internal arc occurs. See “Erection”.



A transformer cubicle can always be positioned with its rear side against the wall.

- Anchor each cubicle of the medium voltage switchgear using four bolts in the floor. See “Erection”.
- Connect the cubicles together using the attachment material supplied. See “Connecting the cubicles”.
- Ensure proper fitment of the end panels. See “Assembly off the end panels”.

In medium voltage switchgears installed in accordance with the above-described installation procedure, the (unlikely) internal arc will always be limited to the compartment in which it has occurred.

## 4.2 Unpacking

The DF-2 cubicles are packed as standard in protective foil and mounted on a euro pallet. The most suitable place for unpacking the cubicles is of course the definitive installation area.

- Clip or cut the straps securing the cubicle to the pallet.
- Carefully remove the protection foil.
- Check against the delivery receipt that the cubicle is complete.
- Check the cubicle for any (transportation) damage.



If parts are missing or damaged, contact the conveyor or SwitchGear Company nv.  
 Seriously damaged cubicles must always be returned to SwitchGear Company nv.

- Carefully lift the cubicle off the pallet.



### CAUTION

The cubicles are fitted with lifting eyes if requested. If you use these fittings, use suitable hoisting and lifting machinery in perfect condition and with sufficient hoisting capacity only. Observe the applicable safety precautions. The handling and operating of hoisting or lifting machinery is restricted to experienced staff within the visible and shouting range of the operator of the hoisting or lifting machinery.

- Remove the pallet.
- Remove the door:
  - Turn the locking latch (in the middle, above the door)
  - Grasp the handle of the door to the cable compartment with both hands.
  - Carefully lift the door out.

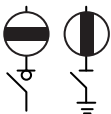

Cubicles fitted with a load break switch and an earthing switch are delivered as standard in the position 'load break switch OPEN – earthing switch CLOSED'. In this position the door is always removable. See "Operation".

- Place the loose door where there is no risk of it being damage.
- Repeat the above steps for each individual cubicle.
- Remove the end panels that have been fitted to one of the cubicles as necessary.

After the used packing material has been disposed of in accordance with the applicable directives, the installation of the cubicles can be started.

### 4.3 Erection

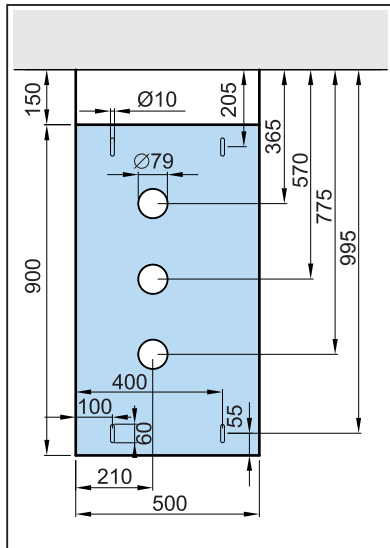

DF-A  
DF-P  
DF-K

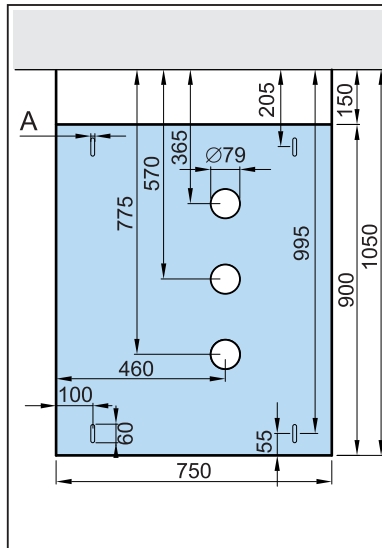

DF-D A=Ø11  
DF-D-W A=Ø10

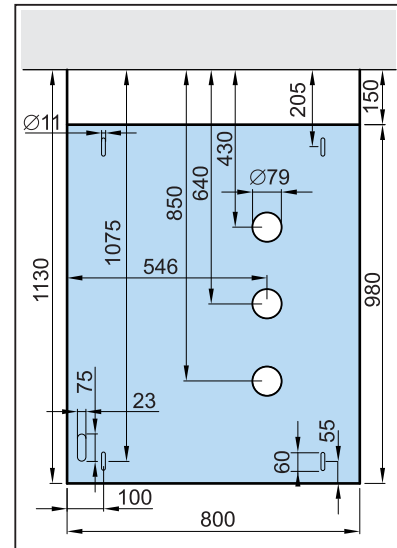

DF-EDN-D

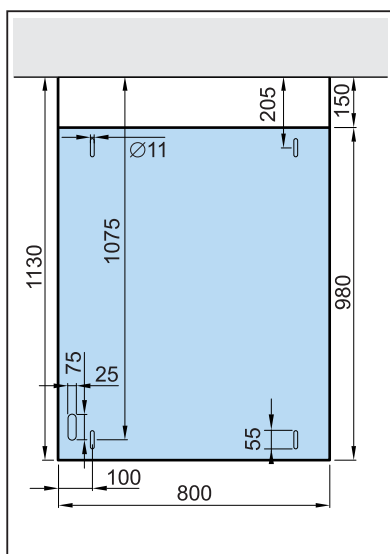

DF-EDN-LK

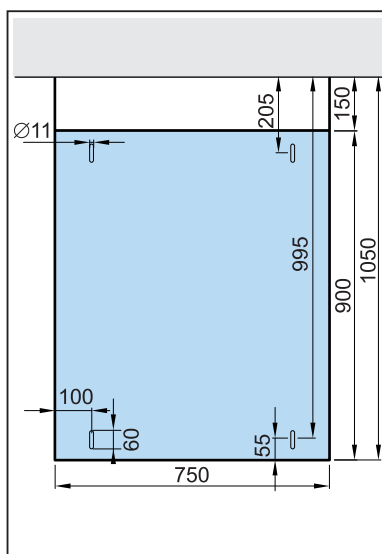

DF-AAD  
DF-LK

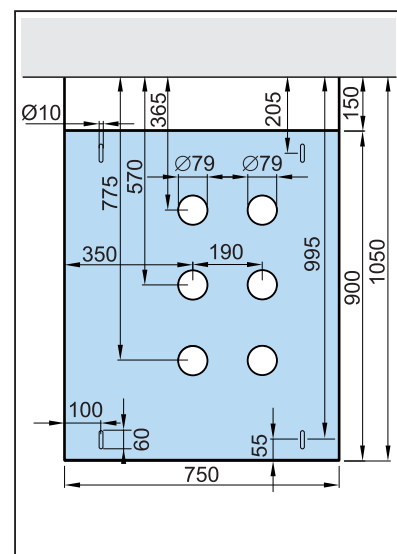

DF-C

4.01



Consult the installation diagram(s), the electrical diagram and the ground plans (fig. 4.01) before starting the actual installation of the medium voltage switchgear.

- Place the first cubicle in its definitive position in the installation area.



Leave **150 mm** free between the rear wall of the cubicle and the wall of the installation area. In this way the over pressure valves of the back plate can operate if (unlikely) there is an internal arc.  
A transformer cubicle can be positioned with its rear side against the wall.

- Level the first cubicle.
- Anchor this first cubicle using 4 bolts to the floor. Use the holes intended for this purpose (fig. 4.02A).
- Disassemble the front panel:
  - Loosen the four hexagonal tap bolts (fig. 4.03C).
  - Remove the four washers (fig. 4.03B).
  - Remove the front panel (fig. 4.03A). The driving mechanism and low voltage compartment is now accessible.
- Position the second cubicle against the first cubicle.

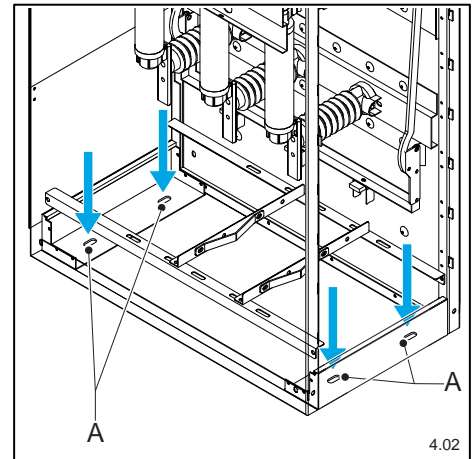

Ensure that the cubicles are exactly in line and stay accurately level in order to enable a torsion free mounting of the housing, earthing copper connection pieces and bus bars.

Any plinths are provided ex factory and will be supplied separately.

Position the cubicles in the order indicated on the installation diagram and the electrical diagram.

- Remove the front panel of the second cubicle.
- Position all other cubicles in the same way and ensure that all front panels have been removed.
- Remove the lifting eyes (if present) from the cubicles. To do this, loosen the bolts.
- The cubicles are now ready to be assembled. See "Cubicle assembly".

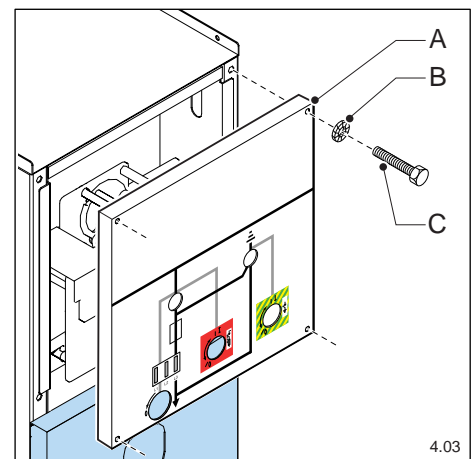



## 4.4 Cubicle assembly

When assembling the cubicles, the following important steps apply:

- Connecting the cubicles
- Fitting the earthing copper connection pieces
- Fitting the bus bars
- Fitting the end panels

### 4.4.1 Connecting the cubicles

A special kit is available for the connecting of the cubicles.

#### 4.4.1.1 Kit as described hereunder

order number	description	number	pos.no.
GR040820	DIN 933 M8x20 hexagonal tap bolt yellow galvanised	6	fig. 4.04A
GR040830	DIN 933 M8x30 hexagonal tap bolt yellow galvanised	2	fig. 4.04B
GR040891	DIN 933 M8x100 hexagonal tap bolt yellow galvanised	1	fig. 4.04C
GR041608	DIN 6798A Ø M8 lock washer	9	fig. 4.04D
GR041308	DIN 6923 M8 nut with collar (Ripp class 10)	9	fig. 4.04E

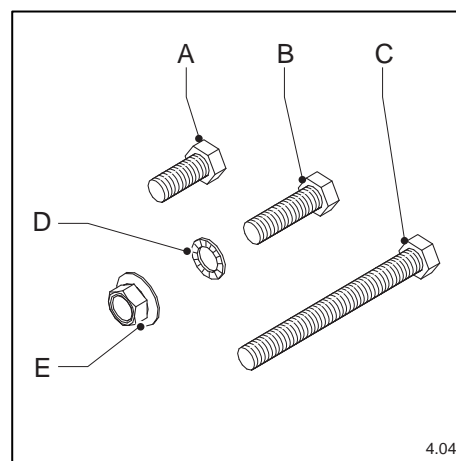

#### 4.4.1.2 Preparation

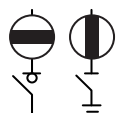

Ensure that the cubicle itself, the immediately following and the previous cubicle are voltage free.

- Ensure that the surface is even and flat, so that the cubicles stay exactly in line and level. Only then a torsion-free fitting is possible.

#### 4.4.1.3 Assembly procedures

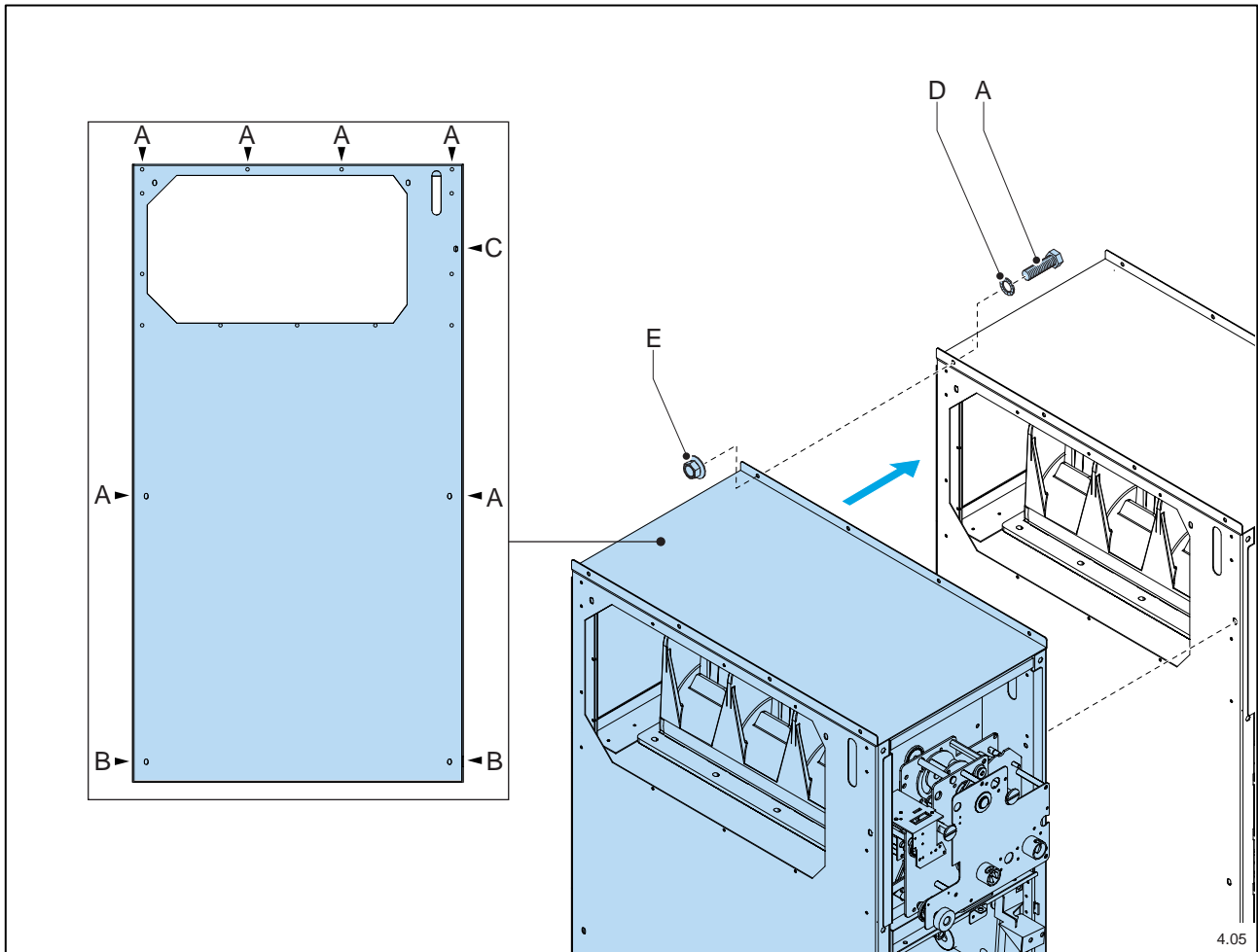

- Connect the cubicles at the height of the roof panels with four hexagonal tap bolts M8x20 (fig. 4.05A), four lock washers Ø M8 (fig. 4.05D) and four hexagonal nuts M8 (fig. 4.05E).
- Hands tighten the assembly.
- Connect the side panels of the cubicles with the two hexagonal tap bolts M8x20 (fig. 4.05A), two hexagonal tap bolts M8x30 (fig. 4.05B), four lock washers Ø M8 (fig. 4.05D) and four hexagonal nuts M8 (fig. 4.05E).
- Hands tighten the assembly.
- Connect the cubicles at the height of the operation and low voltage compartment with four hexagonal tap bolts M8x100 (fig. 4.05C), lock washer Ø M8 (fig. 4.05D) and hexagonal nut M8 (fig. 4.05E).
- Properly tighten all bolt-nut connections.
- Anchor the remaining cubicle(s) to the floor. See “Erection”.

## 4.4.2 Assembly of the earthing copper connection pieces

For connecting the earthing slats (fig. 4.07D) to the bottom side of the cubicles, a special kit is available for each cubicle.

### 4.4.2.1 Kit as described hereunder

order number	description	number	pos. no.
CU317843	Earthing copper connection piece, DF 17,5/24 kV	1	fig. 4.06A



The earthing copper connection piece is a part of the kit that also contains the bus bars (and their fitting material). See “Fitting the bus bars”.

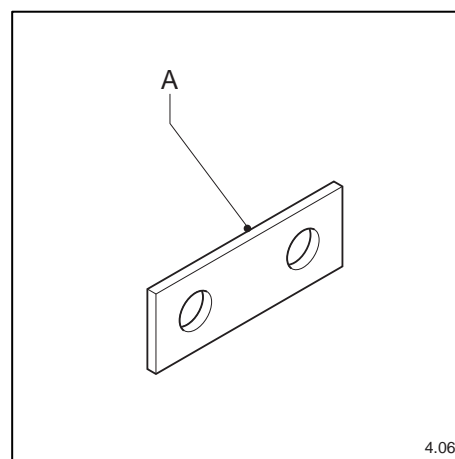

4.06

### 4.4.2.2 Preparation

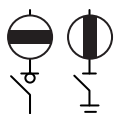

Ensure that the cubicle itself, the immediately following and the previous cubicle are voltage free.

### 4.4.2.3 Assembly procedures

- Loosen the two hexagonal tap bolts M8x30 (fig. 4.07C).
- Remove the two lock washers Ø M8 (fig. 4.07B) and the hexagonal nuts M8 (fig. 4.07E).
- Fit the earthing copper connection piece (fig. 4.07A) using the hexagonal tap bolts M8x30, the lock washers Ø M8 and the hexagonal nuts M8.



Tighten the hexagonal tap bolts to a torque of 20 Nm.

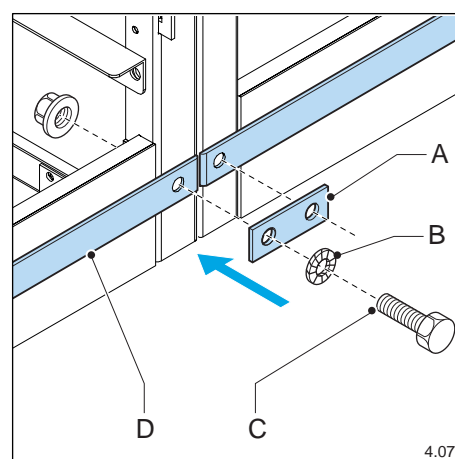

4.07

### 4.4.3 Fitting the bus bars



If there is sufficient room at the sides of the cubicles, the bus bars can be fitted through the opening in the sidewalls.  
 If there is insufficient room (for example when a transformer cubicle is placed against the end cubicle), the roof panel (fig. 4.08A) must be removed from the relevant cubicles.  
 This roof panel is mounted by means of the hexagonal tap bolts (fig. 4.08B), the lock washers (fig. 4.08C), the hexagonal nuts (fig. 4.08D), the rivets (fig. 4.08E) and the self-locking hexagonal collar nuts (fig. 4.08F).

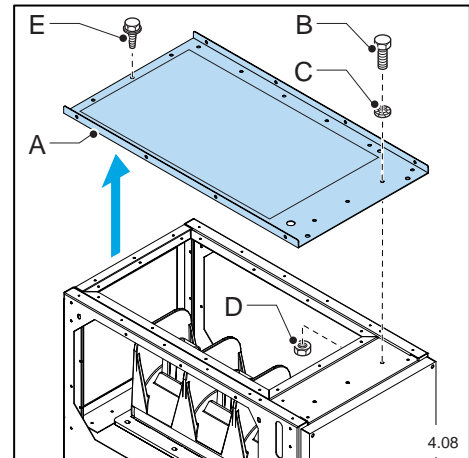

The method of assembly of the bus bars depends on factors such as:

- Current level of the medium voltage switchgear (800 or 1,250 A)
- The number of cubicles that must be connected by means of the bus bars

In all cases, the bus bars must always be assembled so that they are **torsion free**. Sideways tensional forces on the drill holes in the bars or those of the load break switch as a result of incorrectly assembled cubicles are completely unacceptable.

#### 4.4.3.1 Medium voltage switchgear 800 A – available kits for bus bars

The contents of the mounting kits for bus bars may vary, depending on factors such as the current of the medium voltage switchgear and the number of cubicles that must be connected using the bus bars.

Each mounting kits is delivered separately and solidly packed.

##### 4.4.3.1.1 Kit DS178001 as described hereunder

kit composition			
order number	description	number	pos.no.
CU317807	Bus bar, DF A/P L=550 17,5 kV	3	fig. 4.09A
CU317843	Earthing copper connection piece, DF 17,5/24 kV	1	fig. 4.09B
GR017800	set of fitting material	1	fig. 4.09C

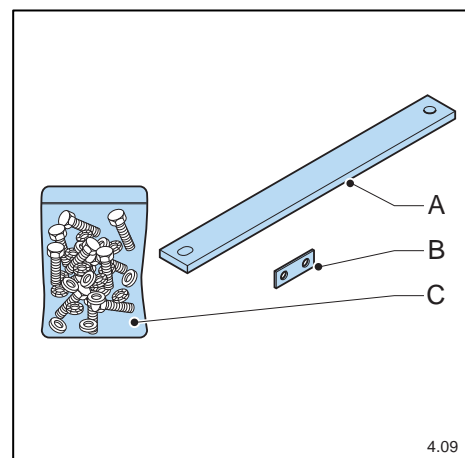

For the assembly of the earthing copper connection pieces see “Assembly of the earthing copper connection pieces”.

#### 4.4.3.1.2 Kit DS178003 as described hereunder

kit composition			
order number	description	number	pos.no.
CU317807	Bus bar, DF A/P L=550 17,5 kV	6	fig. 4.09A
CU317843	Earthing copper connection piece, DF 17,5/24 kV	2	fig. 4.09B
GR017800	set of fitting material	2	fig. 4.09C

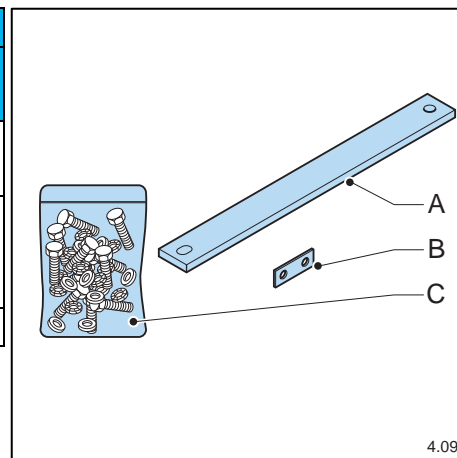

For the assembly of the earthing copper connection pieces see “Assembly of the earthing copper connection pieces”.

#### 4.4.3.1.3 Kit DS178002 as described hereunder

kit composition			
order number	description	number	pos.no.
CU317807	Bus bar, DF A/P L=550 17,5 kV	3	fig. 4.10A
CU317843	Earthing copper connection piece, DF 17,5/24 kV	1	fig. 4.10B
GR017800	set of fitting material	1	fig. 4.10C
CU317808	Space block bus bar, DF A/P/D/EDN 17,5 kV	3	fig. 4.10D

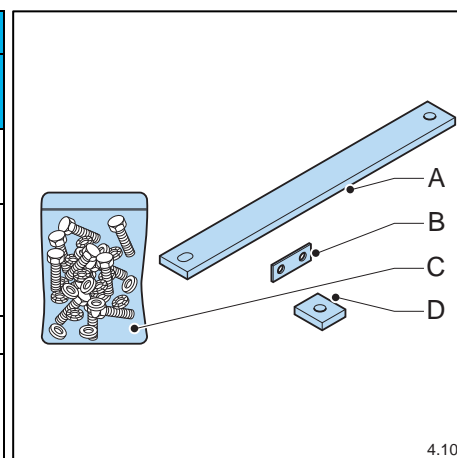

For the assembly of the earthing copper connection pieces see “Assembly of the earthing copper connection pieces”.

#### 4.4.3.1.4 Kit DS178004 as described hereunder

kit composition			
order number	description	number	pos.no.
CU317807	Bus bar, DF A/P L=550 17,5 kV	6	fig. 4.10A
CU317843	Earthing copper connection piece, DF 17,5/24 kV	3	fig. 4.10B
GR017800	set of fitting material	3	fig. 4.10C
CU317808	Space block bus bar, DF A/P/D/EDN 17,5 kV	3	fig. 4.10D

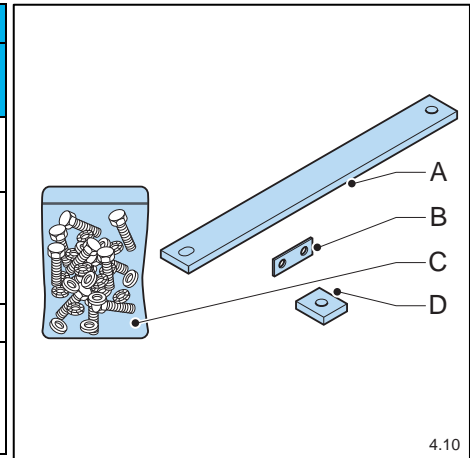

For the assembly of the earthing copper connection pieces see “Assembly of the earthing copper connection pieces”.

#### 4.4.3.1.5 Kit DS178005 as described hereunder

kit composition			
order number	description	number	pos.no.
CU317811	Bus bar, DF-D L=800 17,5 kV	3	fig. 4.09A
CU317843	Earthing copper connection piece, DF 17,5/24 kV	1	fig. 4.09B
GR017800	set of fitting material	1	fig. 4.09C

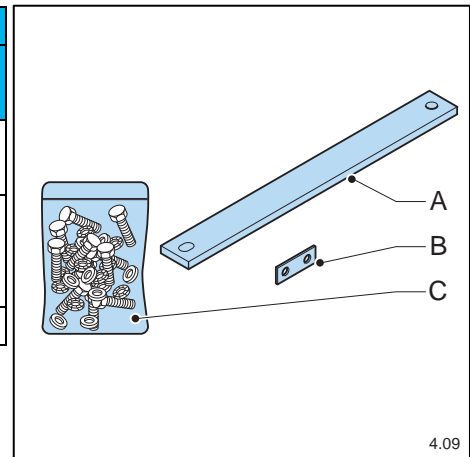

For the assembly of the earthing copper connection pieces see “Assembly of the earthing copper connection pieces”.

#### 4.4.3.1.6 Kit DS178006 as described hereunder

kit composition			
order number	description	number	pos.no.
CU317811	Bus bar, DF-D L=800 17,5 kV	3	fig. 4.10A
CU317843	Earthing copper connection piece, DF 17,5/24 kV	2	fig. 4.10B
GR017800	set of fitting material	2	fig. 4.10C
CU317808	Space block bus bar, DF A/P/D/EDN 17,5 kV	3	fig. 4.10D

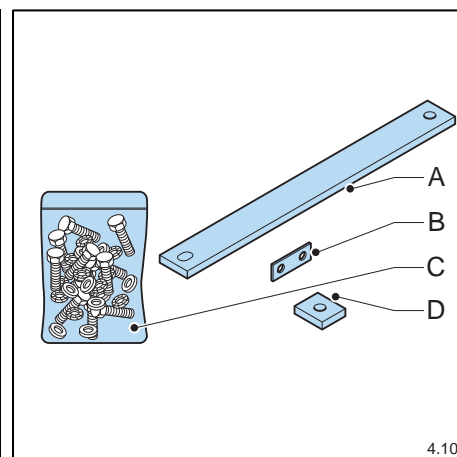

For the assembly of the earthing copper connection pieces see “Assembly of the earthing copper connection pieces”.

#### 4.4.3.2 Medium voltage switchgear 1,250 A - available kits for bus bars

The contents of the assembly kits for bus bars may vary depending on the number of cubicles to be connected using the bus bars.  
Each assembly kit is supplied in a sturdy, separate packing.

##### 4.4.3.2.1 Kit DS178011

kit composition			
order number	description	Number	pos.no.
CU317812	Bus bar, DF EDND L=850 17,5 kV	6	fig. 4.10A
CU317843	Earthing copper connection piece, DF 17,5/24 kV	2	fig. 4.10B
GR017803	set of fitting material	2	fig. 4.10C
CU317808	Space block bus bar, DF A/P/D/EDN 17,5 kV	6	fig. 4.10D

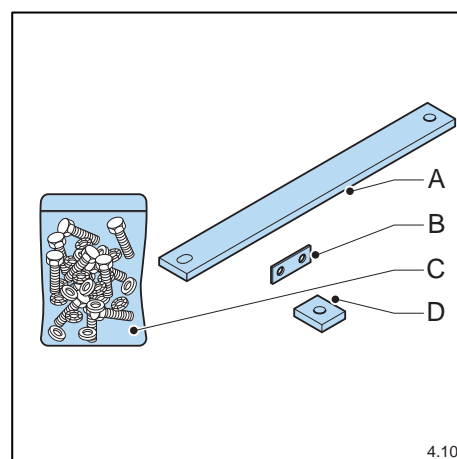

For the assembly of the earthing copper connection pieces see "Assembly of the earthing copper connection pieces".

#### 4.4.3.2.2 Kit DS178012

kit composition			
order number	description	Number	pos.no.
CU317812	Bus bar, DF EDND L=850 17,5 kV	12	fig. 4.10A
CU317843	Earthing copper connection piece, DF 17,5/24 kV	2	fig. 4.10B
GR017804	set of fitting material	2	fig. 4.10C
CU317808	Space block bus bar, DF A/P/D/EDN 17,5 kV	3	fig. 4.10D

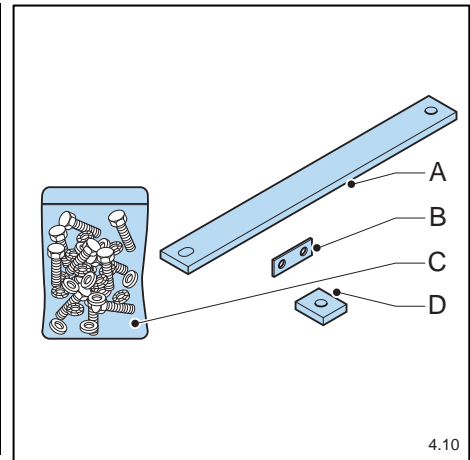

For the assembly of the earthing copper connection pieces see "Assembly of the earthing copper connection pieces".

#### 4.4.3.2.3 Kit DS178013

kit composition			
order number	description	Number	pos.no.
CU317812	Bus bar, DF EDND L=850 17,5 kV	6	4.10A
CU317843	Earthing copper connection piece, DF 17,5/24 kV	1	4.10B
GR017805	set of fitting material	1	4.10C
CU317808	Space block bus bar, DF A/P/D/EDN 17,5 kV	6	4.10D

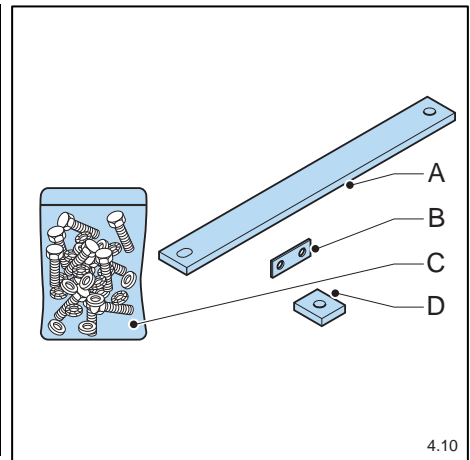

For the assembly of the earthing copper connection pieces see "Assembly of the earthing copper connection pieces".



#### 4.4.3.2.4 Kit DS178014

kit composition			
order number	description	Number	pos.no.
CU317812	Bus bar, DF EDND L=850 17,5 kV	12	fig. 4.10A
CU317843	Earthing copper connection piece, DF 17,5/24 kV	3	fig. 4.10B
GR017806	set of fitting material	3	fig. 4.10C
CU317808	Space block bus bar, DF A/P/D/EDN 17,5 kV	6	fig. 4.10D

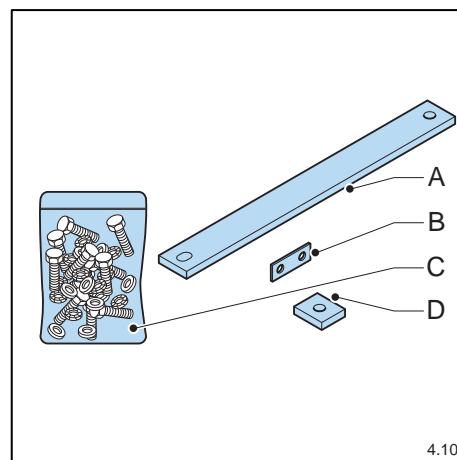

For the assembly of the earthing copper connection pieces see "Assembly of the earthing copper connection pieces".

#### 4.4.3.2.5 Kit DS178015

kit composition			
order number	description	Number	pos.no.
CU317812	Bus bar, DF EDND L=850 17,5 kV	6	fig. 4.10A
CU317843	Earthing copper connection piece, DF 17,5/24 kV	1	fig. 4.10B
GR017807	set of fitting material	1	fig. 4.10C
CU317808	Space block bus bar, DF A/P/D/EDN 17,5 kV	3	fig. 4.10D

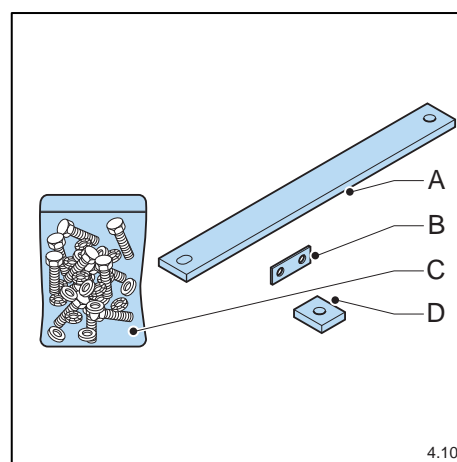

For the assembly of the earthing copper connection pieces see "Assembly of the earthing copper connection pieces".

4.4.3.2.6 Kit DS178016

kit composition			
order number	description	Number	pos.no.
CU317812	Bus bar, DF EDND L=850 17,5 kV	6	fig. 4.10A
CU317843	Earthing copper connection piece, DF 17,5/24 kV	2	fig. 4.10B
GR017808	set of fitting material	2	fig. 4.10C
CU317808	Space block bus bar, DF A/P/D/EDN 17,5 kV	6	fig. 4.10D

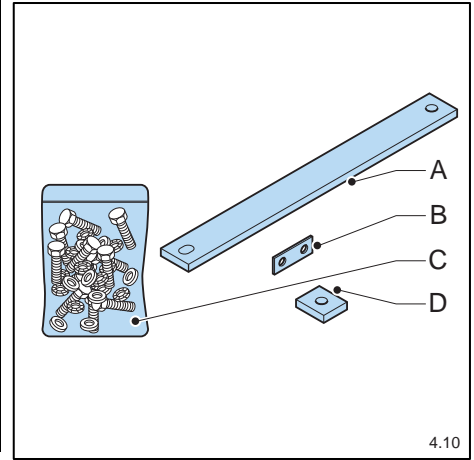

For the assembly of the earthing copper connection pieces see "Assembly of the earthing copper connection pieces".

### 4.4.3.3 Medium voltage switchgear (800 A) composed of two cubicles

Medium voltage switchgears composed of two cubicles are connected with one set of bus bars.

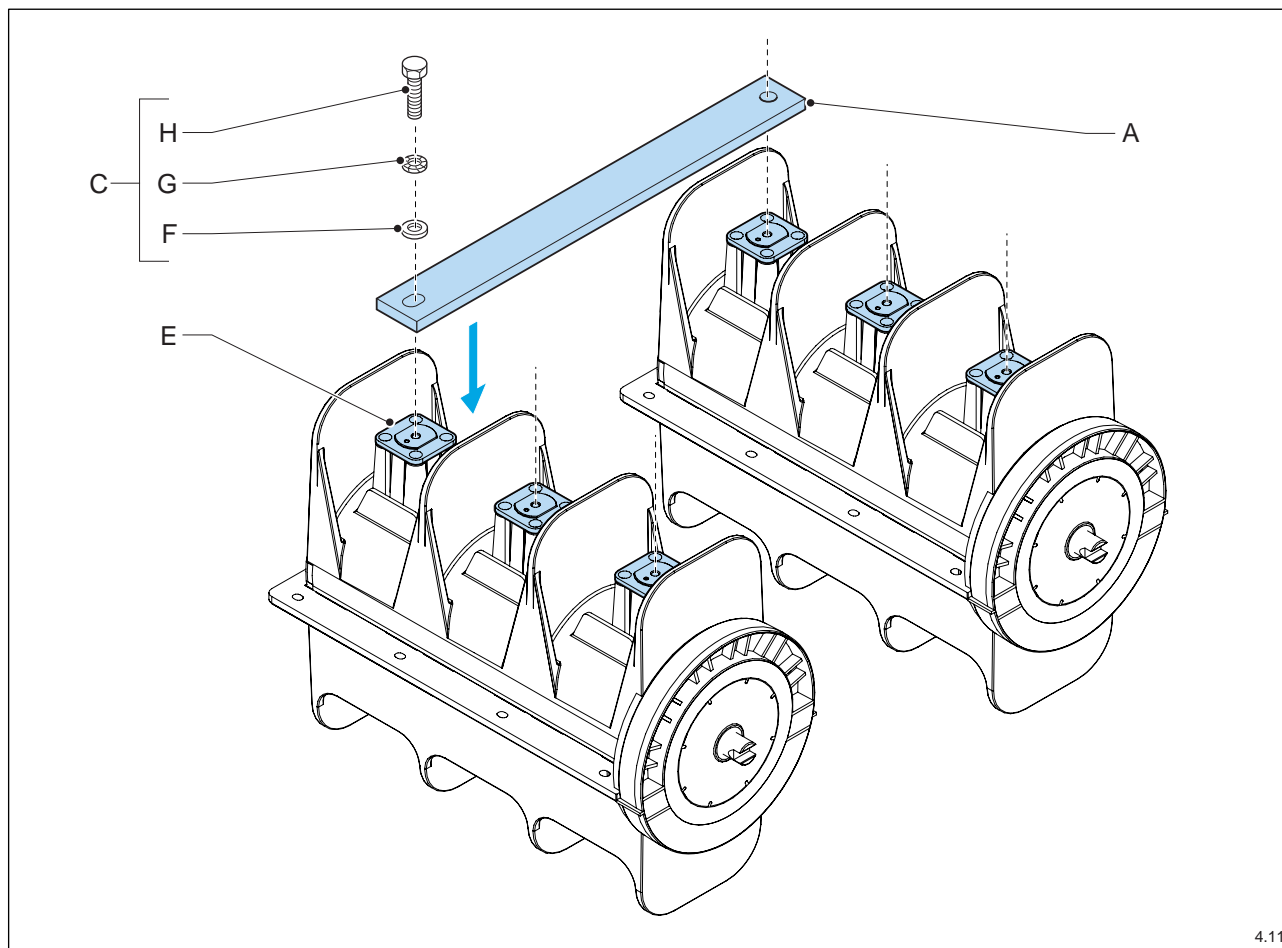

4.11

#### 4.4.3.3.1 Preparation

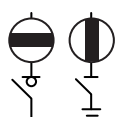

Ensure that the entire medium voltage switchgear is voltage free.

#### 4.4.3.3.2 Assembly procedures



For the contents of the kit, see the table.

- Place the bus bars (fig. 4.11A) on the copper contacts (fig. 4.11E) of the load break switch.
- Attach the bus bars using the fitting material supplied (fig. 4.11C):
  - Hexagonal tap bolts M12x35 (fig. 4.11H)
  - Lock washers Ø M12 (fig. 4.11G)
  - Flat washers Ø M12 (fig. 4.11F).
- Tighten the hexagonal tap bolts to a torque of 35 Nm.

#### 4.4.3.4 Medium voltage switchgear (800 A) composed of three (or a different uneven number of) cubicles

With medium voltage switchgears in which three (or a different uneven number of) cubicles must be connected with the sets of bus bars, the second set of bus bar is fitted **onto** the first set of bus bar, the fourth **onto** the third set of bus bar, etc. In the last cubicle (end cubicle) a space block must be fitted under each bar. This method applies for all medium voltage switchgears with an uneven number of cubicles (and, so, an even number of bar sets).

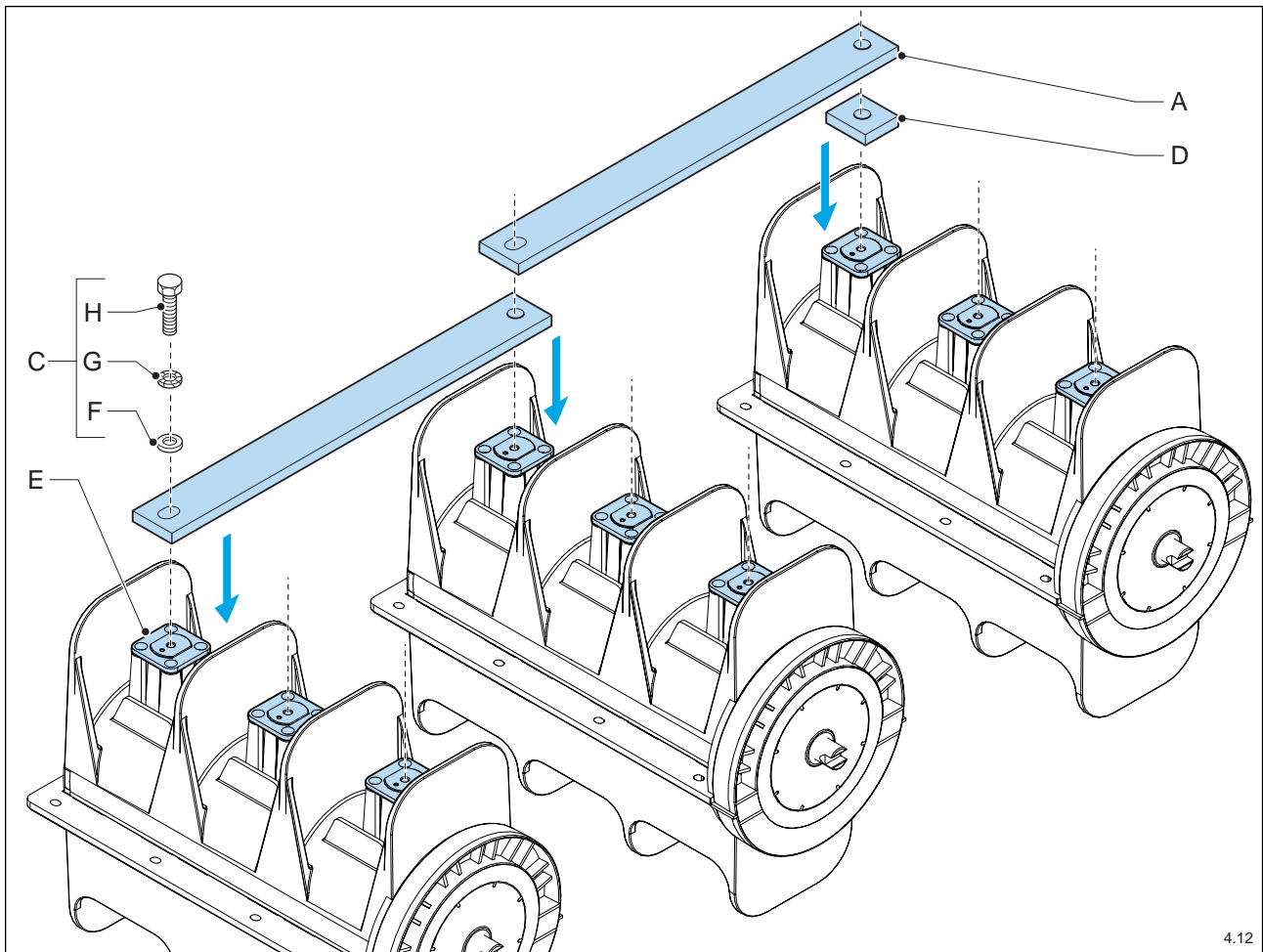

##### 4.4.3.4.1 Preparation

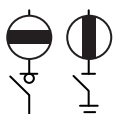

Ensure that the entire medium voltage switchgear is voltage free.

##### 4.4.3.4.2 Assembly procedures



For the contents of the kit, see the table.

- Place the bus bars (fig. 4.12A) and the space blocks (fig. 4.12D) on the copper contacts (fig. 4.12E) of the load break switches.

- Fit the bus bars and the space blocks using the fitting material supplied (fig. 4.12C):
  - Hexagonal tap bolts M12x35 (fig. 4.12H)
  - Lock washers Ø M12 (fig. 4.12G)
  - Flat washers Ø M12 (fig. 4.12F).
- Tighten the hexagonal tap bolts to a torque of 35 Nm.

#### 4.4.3.5 Medium voltage switchgear (800 A) composed by four (or a different even number of) cubicles

With medium voltage switchgears in which four (or a different even number) of cubicles must be connected with the sets of bus bars, the second set of bus bars is fitted **onto** the first and the third set of bus bars, the fourth **onto** the third and the fifth set of bus bars, etc. This method applies for all medium voltage switchgears with an even number of cubicles (and, so, an uneven number of bar sets).

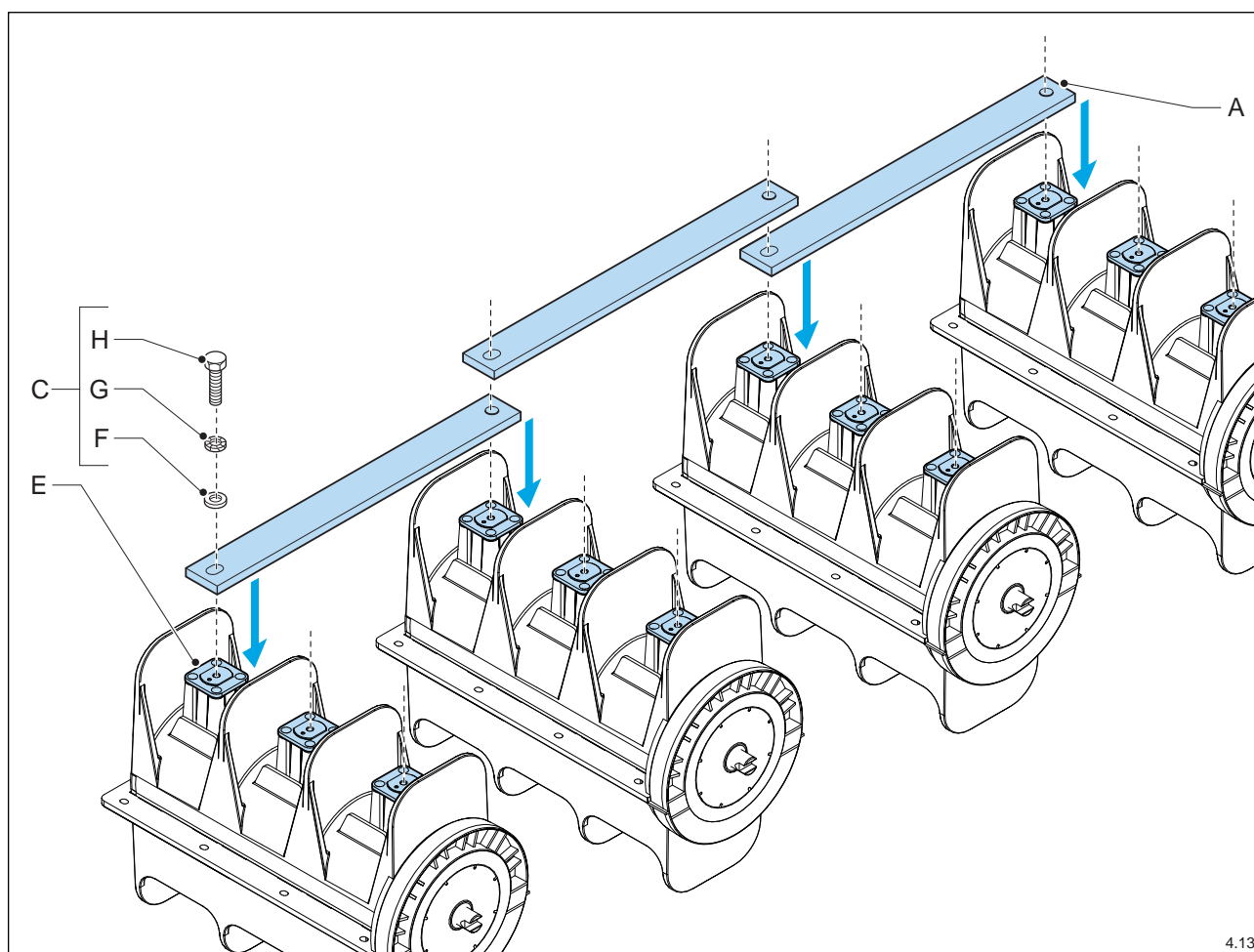

##### 4.4.3.5.1 Preparation

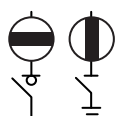

Ensure that the entire medium voltage switchgear is voltage free.

#### 4.4.3.5.2 Assembly procedures



For the contents of the kit, see the table.

- Place the bus bars (fig. 4.13A) alternately on the copper contacts (fig. 4.13E) of the load break switches or on the previous and following bar.
- Fit the bus bars using the fitting material supplied (fig. 4.13C):
  - Hexagonal tap bolts M12x35 (fig. 4.13H)
  - Lock washers Ø M12 (fig. 4.13G)
  - Flat washers Ø M12 (fig. 4.13F).
- Tighten the hexagonal tap bolts to a torque of 35 Nm.

#### 4.4.3.6 Medium voltage switchgear (1,250 A) composed of two cubicles

Medium voltage switchgears composed of two cubicles are connected with one set of double bus bars.

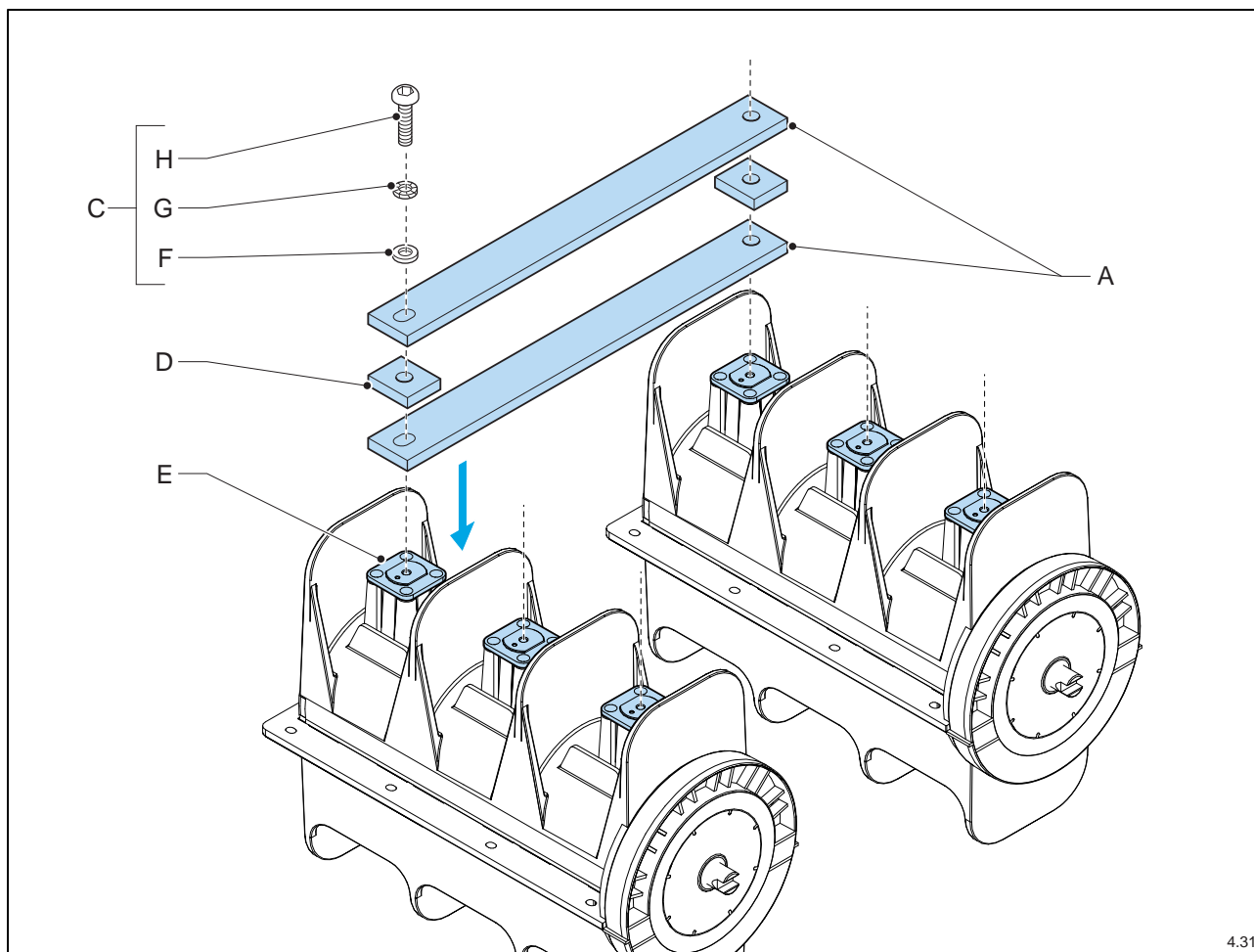

4.31

##### 4.4.3.6.1 Preparation

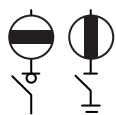

Ensure that the entire medium voltage switchgear is voltage free.

##### 4.4.3.6.2 Assembly procedures



For the contents of the kit, see the table.

- Mount the bottom bars (fig. 4.31A) onto the copper contacts (fig. 4.31E) of the load isolation switch.
- Mount the end pieces (fig. 4.31D).
- Mount the upper bars (fig. 4.31A) onto the end pieces.

- Mount the assembly using the fitting material supplied (fig. 4.31C):
  - round-head screws M12x55 (fig. 4.31H)
  - lock washers Ø M12 (fig. 4.31G)
  - flat washers Ø M12 (fig. 4.31F).
- Tighten the round-head screws to a torque of 35 Nm.

#### 4.4.3.7 Medium voltage switchgear (1,250 A) composed of three (or another odd number of) cubicles

With medium voltage switchgears in which three (or another odd number of) cubicles must be connected with the double sets of bus bars, the second double set of bus bars is fitted onto the first double set of bus bars, the fourth onto the third double set of bus bars, etc. In the last cubicle (end cubicle) an end piece must be fitted underneath each bar. This method applies to all medium voltage boards with an odd number of cells (and hence an even number of bar sets).

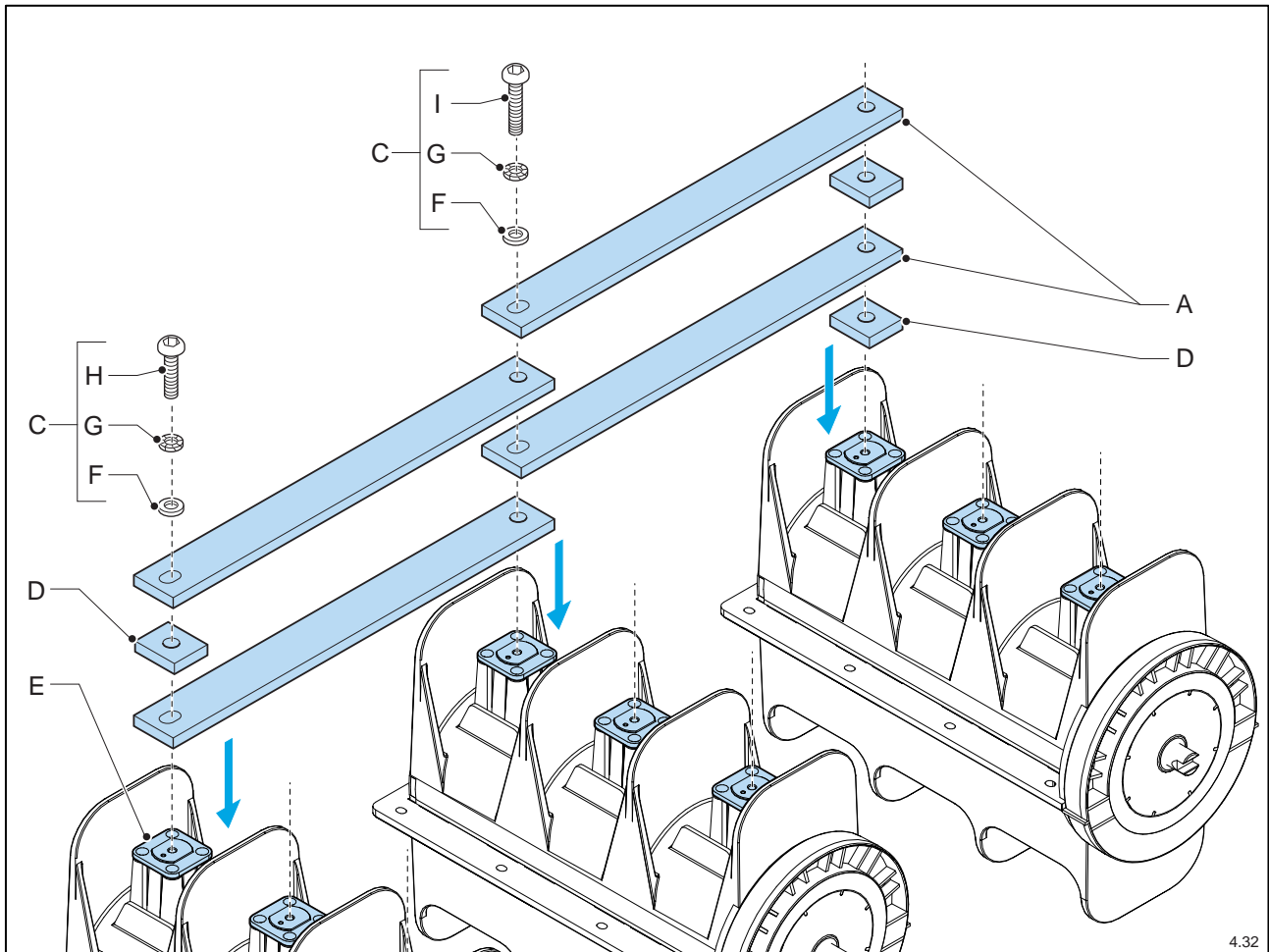

##### 4.4.3.7.1 Preparation

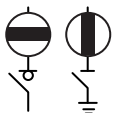

Ensure that the entire medium voltage switchgear is voltage free.



#### 4.4.3.7.2 Assembly procedures



For the contents of the kit, see the table.

- Fit the double bus bars (fig. 4.32A) and the end pieces (fig. 4.32D) in the way shown onto the copper contacts (fig. 4.32E) of the load isolation switches.
- Mount the assembly using the fitting material supplied (fig. 4.32C):
  - round-head screws M12x55 (fig. 4.32H) and M12x60 (fig. 4.32I)
  - lock washers Ø M12 (fig. 4.32G)
  - flat washers Ø M12 (fig. 4.32F).
- Tighten the round-head screws to a torque of 35 Nm.

#### 4.4.3.8 Medium voltage switchgear (1,250 A) composed by four (or another even number of) cubicles

With medium voltage switchgears in which four (or another even number of) cubicles must be connected with the double sets of bus bars, the second double set of bus bars is fitted onto the first and the third double sets of bus bars, the fourth onto the third and the fifth double sets of bus bars, etc. This method applies for all medium voltage boards with an even number of cells (and hence an odd number of bar sets).

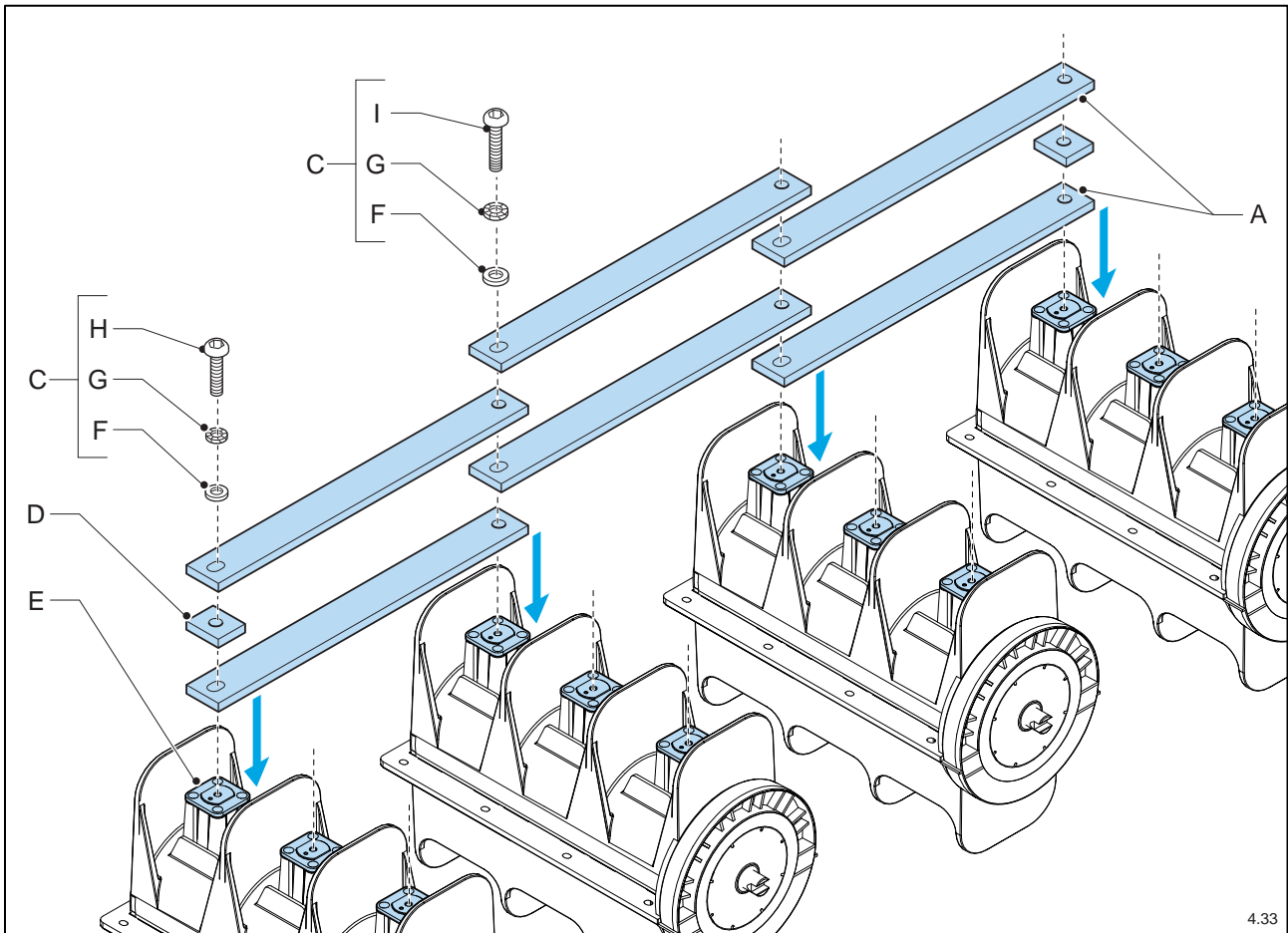

##### 4.4.3.8.1 Preparation

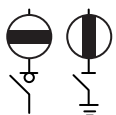

Ensure that the entire medium voltage switchgear is voltage free.

##### 4.4.3.8.2 Assembly procedures



For the contents of the kit, see the table.

- Fit the double bus bars (fig. 4.33A) and the end pieces (fig. 4.33D) in the way shown onto the copper contacts (fig. 4.33E) of the load isolation switch.

- Mount the assembly using the fitting material supplied (fig. 4.33C):
  - round-head screws M12x55 (fig. 4.33H) and M12x60 (fig. 4.33I)
  - lock washers Ø M12 (fig. 4.33G)
  - flat washers Ø M12 (fig. 4.33F).
- Tighten the round-head screws to a torque of 35 Nm.

#### 4.4.4 Assembly of the end panels

For the assembly of the left and right end panels, a special kit is available for each end panel.

##### 4.4.4.1 Kit DF117500 as described hereunder

order number	description	number	pos. no.
GR040820	DIN 933 M8x20 hexagonal tap bolt yellow galvanised	2x8	fig. 4.14A
GR040610	DIN 933 M6x10 hexagonal tap bolt yellow galvanised	2x14	fig. 4.14B
GR040855	DIN 933 M8x55 hexagonal tap bolt yellow galvanised	2x1	fig. 4.14C
GR041606	DIN 6798A Ø M6 lock washer yellow galvanised	2x14	fig. 4.14D
GR041608	DIN 6798A Ø M8 lock washer yellow galvanised	2x9	fig. 4.14E
GR041308	DIN 6923 M8 nut with collar (Ripp class 10)	2x9	fig. 4.14F
DF021701	end panel	2x1	fig. 4.14G

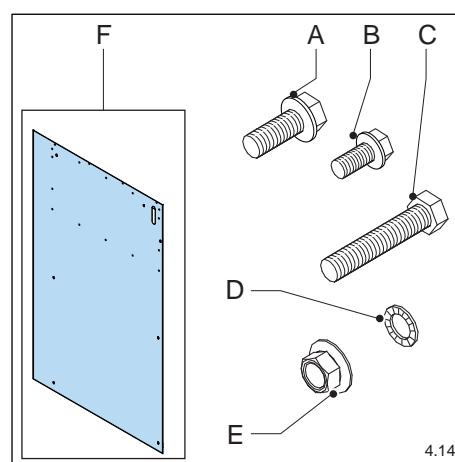

The assembly kit also contains the following items:

order number	description	number
DF045600	Operating handle	1
AG400001	Instruction card DF-2 / vitale 5	1
AG602301	user's manual DF-2 medium voltage switchgear	1



Please present the instruction card in the installation area, making sure that it is clearly visible for the operator(s).

#### 4.4.4.2 Preparation

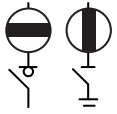

Ensure that the cubicle itself and the immediately following or previous cubicles are voltage free.

#### 4.4.4.3 Assembly procedures

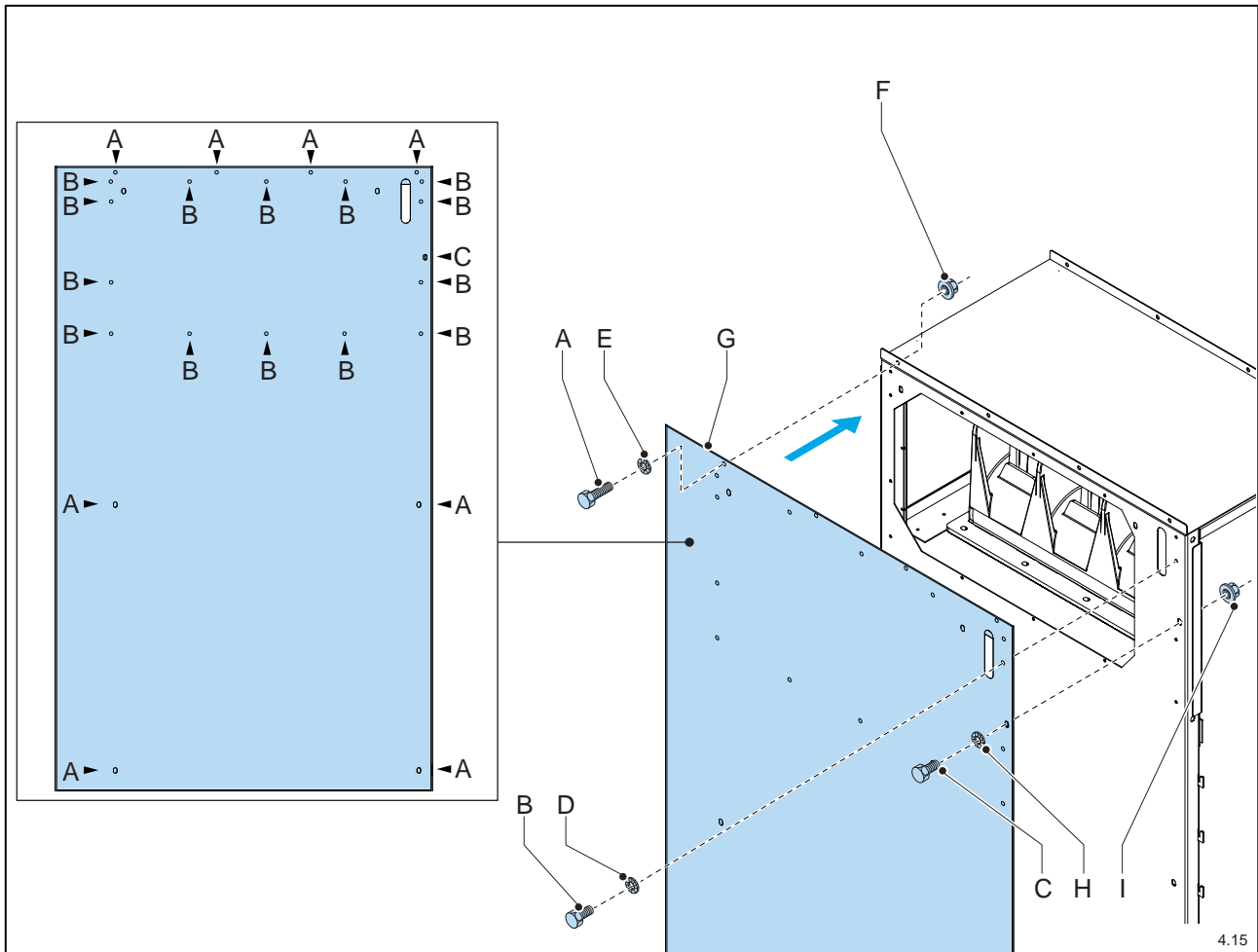

- Position the end panel (fig. 4.15G) against the sidewall of the cubicle, so that the holes in the end panel and the side panel are aligned.
- Mount the end panel using the fitting material supplied:
  - the hexagonal tap bolt M8 (fig. 4.15C), a lock washer  $\text{Ø}$  M8 (fig. 4.15H) and a nut M8 (fig. 4.15I)
  - the eight hexagonal tap bolts M8 (fig. 4.15A), the other eight lock washers  $\text{Ø}$  M8 (fig. 4.15E) and the other eight nuts M8 (fig. 4.15F)
  - the 14 hexagonal tap bolts M6 (fig. 4.15B), and the 14 lock washers  $\text{Ø}$  M6 (fig. 4.15D)

## 4.5 Greasing the earthing switch, the earthing knife spoons and the damping blocks

With DF-2 cubicles with an earthing switch, a thin, evenly applied layer of the supplied SGC-grease (order number: GR002002) must be applied to the following parts:

- earthing switch
- earthing knife (fig. 4.16B) and damping blocks (fig. 4.16A): approx. 0.5 mm thick layer

**i** The moving, turning and hinging parts of the drive mechanisms have been lubricated for life in the factory. All sliding bearings are made of steel with a coating of self-lubricating bronze and a final coating of PTFE. All other bearings (ball bearings and needle bearings) are the closed type and have been lubricated internally for their entire life.

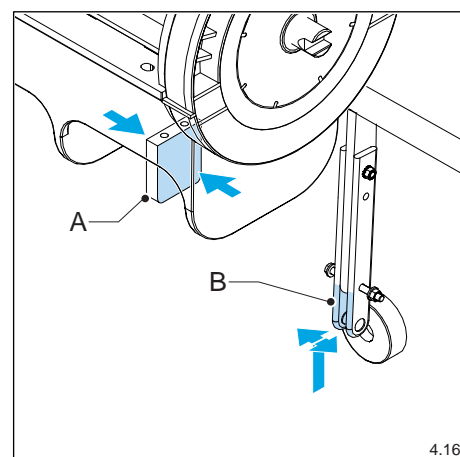

With DF-2 cubicles not only the earthing switch, but also the earthing knife spoons (fig. 4.17B) and damping blocks (fig. 4.17A) of the **main earthing switch**, as well as the earthing knife spoons (fig. 4.17C) and damping blocks (fig. 4.17D) of the **second earthing switch** (auxiliary earthing switch) is lubricated with an approx. 0.5 mm thick, evenly applied layer of the supplied SGC grease (order number: GR002002).

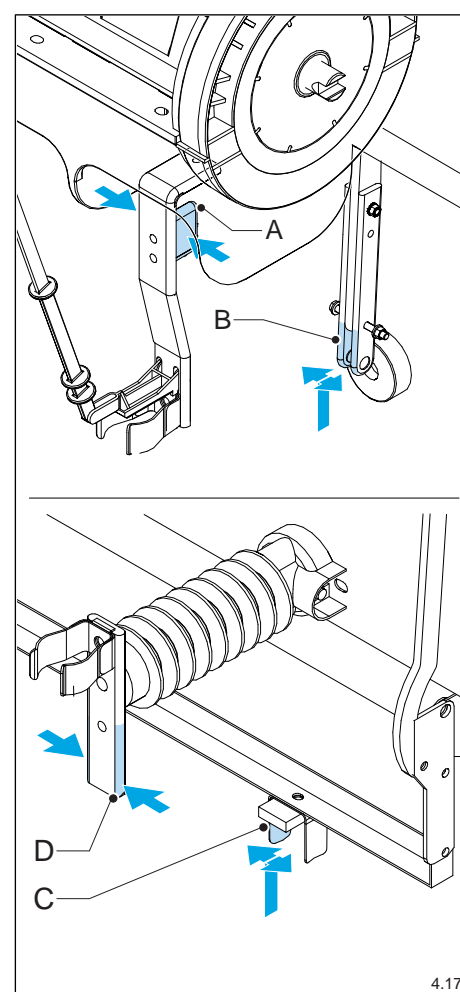

## 4.6 Fitting the front panels

- Carefully check whether there are any tools or fitting materials left in the mechanical drive and low voltage compartment.
- Assemble (for each cubicle) any options. See “Assembly of options”.
- Assemble the front panel (fig. 4.03A) using the four hexagonal tap bolts (fig. 4.03C) and the spring washers (fig. 4.03B).



After assembly of the front panels, the floor pans can be fitted within all cubicles (with the exception of the DF-T). In cubicles that required cable connection, the connection of the cables is usually carried out at the same time as the assembly of the floor pans. See “Assembly of the floor pans”.

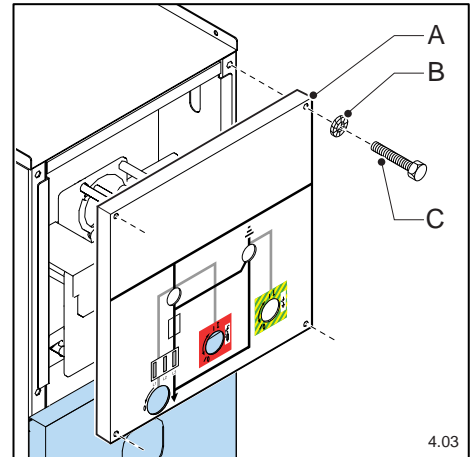

## 4.7 Assembly of the floor pans

Considering the fact that when installing the cubicles, the assembly of the floor pans and the connection of the cables happens almost simultaneously, the descriptions of these actions are combined.

The following applies in all circumstances:



Connection of the cable can only be carried out by qualified and authorised staff in the service of the power supply company, using the attachment material supplied by SwitchGear Company nv. The cables may not ever cross.

### 4.7.1 Kit DS178007

order number	description	number	pos. no.
DF022611	floor pan	4	fig. 4.18A
DF980241	feeding rubber	3	fig. 4.18B
GR040979	M6x20 flange bolt, yellow galvanised	8	fig. 4.18C
GR041606	DIN 934 Ø M6 lock washer, yellow galvanised	9	fig. 4.18D
GR041006	DIN 934 M6 hexagonal nut	8	fig. 4.18E

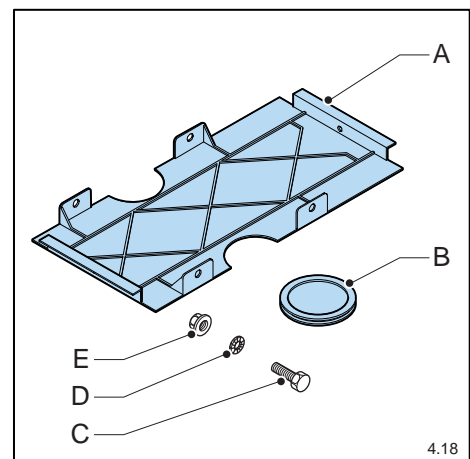

## 4.7.2 Preparation

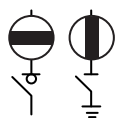

Ensure that the concerned cubicle is voltage free.

## 4.7.3 Assembly procedures

- For each cable fitting (fig. 4.19G), loosen the hexagonal tap bolts a few turns so that the cable fitting depth can be adjusted.

**i** Depending on the thickness of the cable, it may be necessary to completely disassemble the cable fittings.

- Disassemble the clamp (fig. 4.19F) for each cable fitting or loosen them at one side.
- Fit the rear floor pan (fig. 4.19A).
- Attach the floor pan on either side of the frame with the flange bolt (fig 4.19C), the lock washer (fig. 4.19D) and the nut (fig. 4.19E).
- Make a few cuts with a sharp knife in the grommet rubber (fig. 4.20B).
- Slide the grommet rubber over the cable sleeve (fig. 4.20H).
- Connect the cable to the connecting terminal:
  - Place the washer (fig. 4.20L) on the connecting terminal.
  - Fit the cable using the washer (fig. 4.20K) the lock washer (fig. 4.20J) and the nut (fig. 4.20I).
- Refit the clamp (fig. 4.21F) on the cable fitting.
- Secure the cable fitting by tightening the hexagonal tap bolts on either side.
- Slide the grommet rubber (fig. 4.21B) to the correct height on the cable.
- Connect the earthing cable (fig. 4.21M) using the nut (fig. 4.21N) to the earthing strip.

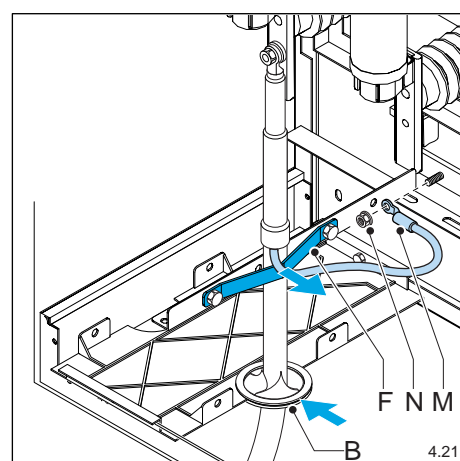
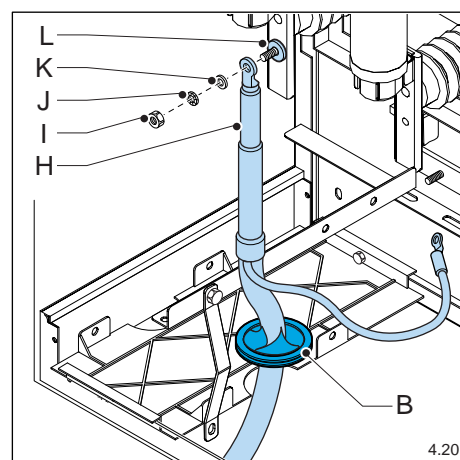
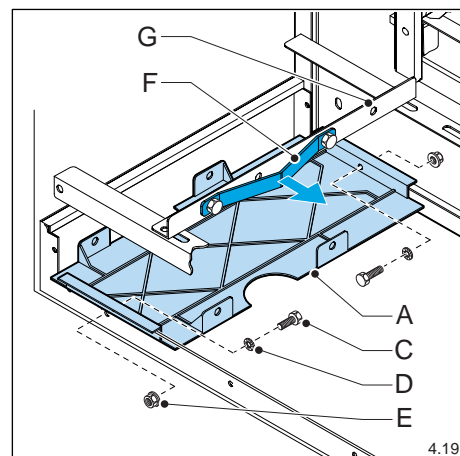

- Fit the second floor pan (fig. 4.22A) in the cubicle, so that the grommet rubber is secured by the two floor pans.
- Attach the floor pan on either side of the frame with the flange bolt (fig 4.22C), the lock washer (fig. 4.22D) and the nut (fig. 4.22E).
- Attach the second floor pan to the rear floor pan using the hexagonal tap bolts (fig. 4.22O), the lock washer (fig. 4.22P) and the nuts (fig. 4.22Q).
- Continue as described earlier. Continue to work methodically towards the door opening.

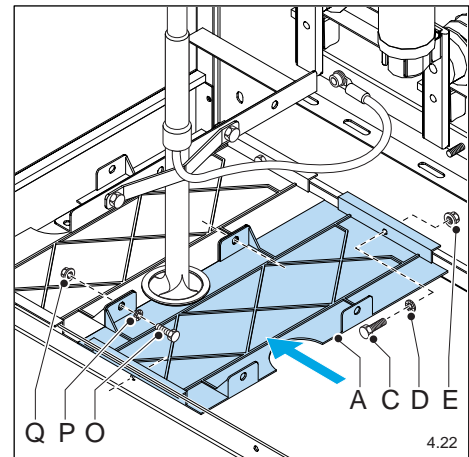

After assembling the four floor pans (and connecting the cables) the doors can be refitted on the cubicles.

## 4.8 Refitting the door

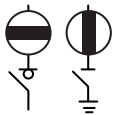

For refitting the door, the load break switch must be in the OPEN position and the earthing switch must be in the CLOSED position. See “Operation”.

- Carefully check whether there are any tools or fitting materials left in the cable compartment.
- Check all connections.
- Fit the door (fig. 4.23B) of the cable compartment:
  - Grasp the door by the handle with both hands (fig. 4.23D).
  - Carefully position the door in the supports.
  - Push the door downwards.
- Lock the door with a reliable padlock (fig. 4.23C) on the locking latch (fig. 4.23A).

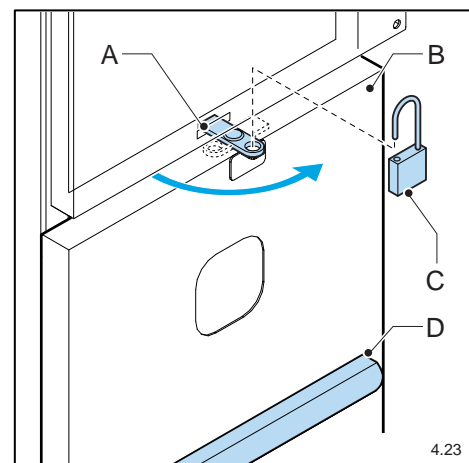

A specially appointed, qualified operator must retain the keys only.



## 4.9 Measuring the phase sequence

**i** The phase sequence is usually measured between the DF-A cubicles. Through the voltage indicators (fig. 4.24A) the phase sequence can be measured easily at the front panel.

- Measure with a voltmeter (fig. 4.24B) between the **corresponding** phases on the left side of the cubicle.

**i** If no voltage is measured, the phase sequence is correct. Measuring the voltage between two **different** phases allows you to check the correctness of the measure. Of course, in this case a voltage will be measured.

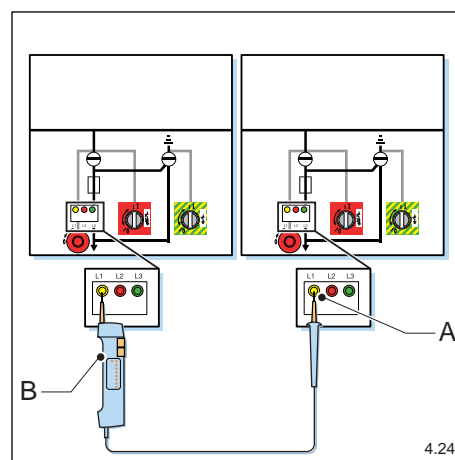

## 4.10 Initial commissioning

The actual connection to the power supply and the initial commissioning of the medium voltage switchgear can be done by qualified and trained staff employed by the power supply company only, observing the locally applicable safety regulations.



## 5 USE

### 5.1 Safety instructions – use

- Also see “General safety directions and instructions”.
- Use of the medium voltage switchgear is restricted to qualified and trained operators, while observing the locally applicable safety instructions and guidelines.
- Ensure that when using the medium voltage switchgear the door is always properly closed and locked with a reliable padlock. When a door is open, switching is not possible.

### 5.2 Operation

Depending on the version, the medium voltage switchgear is fitted with (a number of) the following controls and indicators:

- Synoptic diagram (see “Synoptic diagram”)
- Operating handle
- Load break switch (single)
- Load break switch (double)
- Earthing switch
- Capacitive voltage indicators
- Button release for the opening of the load break switch
- Low voltage switch
- Circuit breaker



The function and use of these controls and indicators is described in function of the specificity of the switchgear

In the following table, the various cubicle types are shown with the description of the function for each cubicle in the form of a cross-reference.

Cubicle types with interrupting function								
	DF-A	DF-P	DF-D	DF-D-W	DF-EDN-D	DF-EDN-LK	DF-AAD	DF-LK
<b>Combination load break switch earthing switch</b>	X	X	X	X	X	-	-	-
<b>Capacitive voltage indicators</b>	X	X	X	-	-	-	-	-
<b>Double load break switch</b>	-	-	-	-	-	X	X	X
<b>Combination fuse /load break switch</b>	-	X	-	-	-	-	-	-
<b>Circuit breaker</b>	-	-	X	X	X	-	X	-
<b>Low voltage switch</b>	-	-	-	-	-	-	-	-

Cubicle types without interrupting function			
	DF-K	DF-T	DF-C
Combination load break switch earthing switch	-	-	-
Capacitive voltage indicators	-	-	-
Double load break switch	-	-	-
Combination fuse /load break switch	-	-	-
Circuit breaker	-	-	-
Low voltage switch	-	-	-

### 5.2.1 Operating the combination load break switch earthing switch

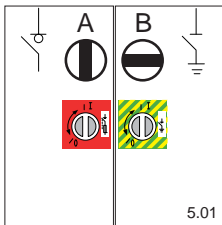

The normal “in use” position is as follows:

- Load break switch CLOSED (the indicator (fig. 5.01A) on the synoptic diagram is vertical)
- Earthing switch OPEN (the indicator (fig. 5.01B) on the synoptic diagram is horizontal)

In this position the earthing switch is automatically locked. It is not possible to close the earthing switch.

#### 5.2.1.1 Opening the load break switch and closing the earthing switch

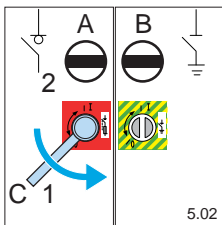

- Place the operating handle (fig. 5.02C) on the operating shaft of the load break switch.
- Turn the operating shaft **anticlockwise** until the load break switch is heard to open (1).  
The indicator (fig. 5.02A) on the synoptic diagram moves to the horizontal position and the earthing switch is automatically unlocked (2).

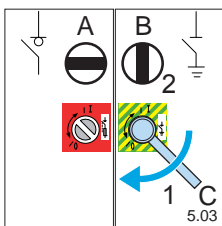

- Place the operating handle (fig. 5.03C) on the operating shaft of the earthing switch.
- Turn the operating shaft **clockwise** until the earthing switch is heard to close (1).  
The indicator (fig. 5.03B) on the synoptic diagram moves to the vertical position (2).  
If necessary, the door can now be opened.



Turn anticlockwise = open switch  
Turn clockwise = close switch

### 5.2.1.2 Opening the earthing switch and closing the load break switch

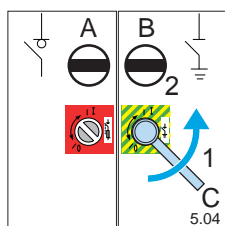

- Ensure that the door of the cable compartment is closed. See “Refitting the door”.
- Place the operating handle (fig. 5.04C) on the operating shaft of the earthing switch.
- Turn the operating shaft **anticlockwise** until the earthing switch is heard to open (1).  
The indicator (fig. 5.04B) on the synoptic diagram moves to the horizontal position (2).

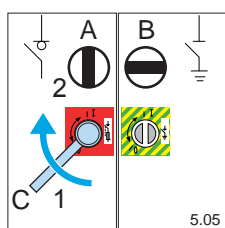

- Place the operating handle (fig. 5.05C) on the operating shaft of the load break switch.
- Turn the operating shaft **clockwise** until the load break switch is heard to close (1).  
The indicator (fig. 5.05A) on the synoptic diagram moves to the vertical position (2). The cubicle is now ready for putting into operation.



Turn anticlockwise = open switch  
Turn clockwise = close switch

### 5.2.2 Reading the capacitive voltage indicators

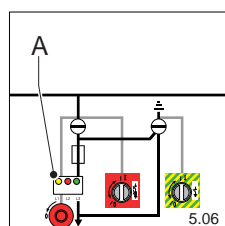

The capacitive voltage indicators (fig. 5.06A) make it possible to measure the phase sequence (on first commissioning). See “Measuring the phase sequence”. With the voltage indicators it can also be established whether fuses have tripped (in DF-P cubicles) and whether (with the load break switch in the position OPEN) there is still voltage present in the cables.

### 5.2.3 Operation of the double load break switch

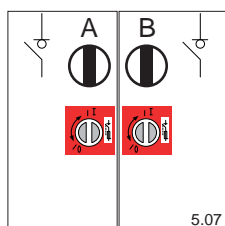

- During normal operation the position is as follows:
- Initial load break switch **CLOSED** (the indicator (fig. 5.07A) on the synoptic diagram is vertical)
  - Second load break switch **CLOSED** (the indicator (fig. 5.07B) on the synoptic diagram is vertical)

The two load break switches can be operated independently of each other.

#### 5.2.3.1 Operation of the double load break switch

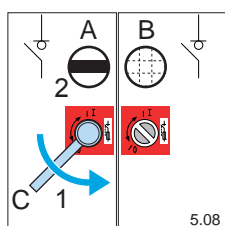

- Place the operating handle (fig. 5.08C) on the operating shaft of the first load break switch.
- Turn the operating shaft **anticlockwise** until the first load break switch is heard to open (1).  
The indicator (fig. 5.08A) on the synoptic diagram moves to the horizontal position (2).

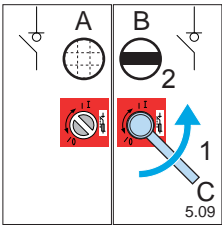

- Place the operating handle (fig. 5.09C) on the operating shaft of the second load break switch.
- Turn the operating shaft **anticlockwise** until the second load break switch is heard to open (1).  
The indicator (fig. 5.09B) on the synoptic diagram moves to the horizontal position (2).  
If necessary, the door can now be opened.



Turn anticlockwise = open switch  
Turn clockwise = close switch

### 5.2.3.2 Closing the double load break switch

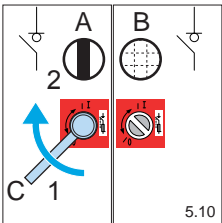

- Ensure that the door of the cable compartment is closed.  
See “Refitting the door”.
- Place the operating handle (fig. 5.10C) on the operating shaft of the first load break switch.
- Turn the operating shaft **clockwise** until the initial load break switch is heard to close (1).  
The indicator (fig. 5.10A) on the synoptic diagram moves to the vertical position (2).

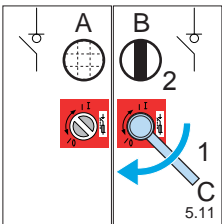

- Place the operating handle (fig. 5.11C) on the operating shaft of the second load break switch.
- Turn the operating shaft **clockwise** until the second load break switch is heard to close (1).  
The indicator (fig. 5.11B) on the synoptic diagram moves to the vertical position (2).



Turn anticlockwise = open switch  
Turn clockwise = close switch

### 5.2.4 Operation of the combination load break switch – fuse

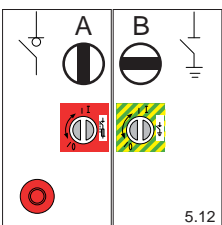

The position during normal use is as follows:

- Load break switch CLOSED (the indicator (fig. 5.12A) on the synoptic diagram is vertical)
- Earthing switch OPEN (the indicator (fig. 5.12B) on the synoptic diagram is horizontal)

In this position the earthing switch is automatically locked. It is not possible to close the earthing switch.

### 5.2.4.1 Opening the load break switch and closing the earthing switch

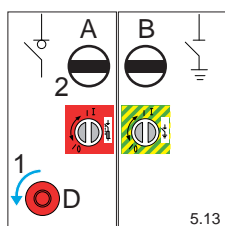

- Turn the red button (fig. 5.13D) **anticlockwise** until the load break switch is heard to open (1).  
The indicator (fig. 5.13A) on the synoptic diagram moves to the horizontal position and the earthing switch is automatically unlocked (2).

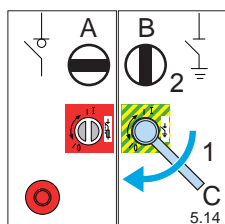

- Place the operating handle (fig. 5.14C) on the operating shaft of the earthing switch.
- Turn the operating shaft **clockwise** until the earthing switch is heard to close (1).  
The indicator (fig. 5.14B) on the synoptic diagram moves to the vertical position (2).



Turn anticlockwise = open switch  
Turn clockwise = close switch

- Check with the capacitive voltage indicators (with the load break switch in the position OPEN) whether there is still voltage in the cables.  
The capacitive voltage indicators must be extinguished.  
If necessary, the door can now be opened.

### 5.2.4.2 Opening the earthing switch and closing the load break switch

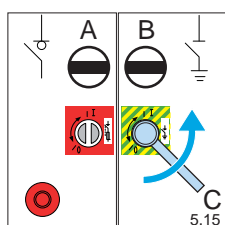

- Ensure that the door of the cable compartment is closed. See "Refitting the door".
- Place the operating handle (fig. 5.15C) on the operating shaft of the earthing switch.
- Turn the operating shaft **anticlockwise** until the earthing switch is heard to open.

The indicator (fig. 5.15B) on the synoptic diagram moves to the horizontal position.

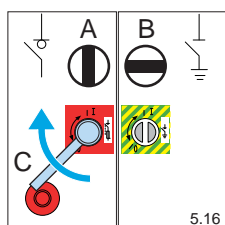

- Place the operating handle (fig. 5.16C) on the operating shaft of the load break switch.
- Turn the operating shaft **clockwise** until the load break switch is heard to close.

The indicator (fig. 5.16A) on the synoptic diagram moves to the vertical position. The cubicle is now ready for putting into operation.



Turn anticlockwise = open switch  
Turn clockwise = close switch

### 5.2.5 Operating the circuit breaker and the relay



See the documentation supplied by the circuit breaker manufacturer.

### 5.2.6 Operating the low voltage switch

During normal operation the low voltage switch is CLOSED.

- Pull the low voltage switch forwards with both hands at the same time to open the low voltage switch.
- Push the low voltage switch backwards with both hands at the same time to close the low voltage switch.



Always cut off the power supply. On the safety cubicle switch the load break switch to OPEN and the earthing switch to CLOSED.



## 6 MAINTENANCE

### 6.1 Safety instructions – maintenance

- Also see “General safety directions and instructions”.
- The maintenance actions described are restricted to qualified and trained operators. Always observe the local applicable safety instructions and guidelines.
- All other, not indicated maintenance tasks are restricted to trained and qualified service personnel (employed by the power supply company).
- Ensure that the whole medium voltage switchgear is voltage free before you carry out the maintenance actions described.
- Only put the medium voltage switchgear back into operation after all the front panels and doors that have been removed have been refitted and the work carried out has been carefully checked.
- Never leave tools or fitting material in or on top of the medium voltage switchgear.

### 6.2 Maintenance - general

The DF-2 cubicles have been designed to operate problem free with a minimum of maintenance. To guarantee this a few simple maintenance and cleaning actions are necessary. If you exercise the necessary care and carry out the actions described faithfully, any problems will usually be discovered and corrected before they lead to a major problem

Considering that the maintenance intervals, depending on the specific operating circumstances, can vary a lot, no maintenance intervals are stated.

Exceptions to this are the following tasks:

interval	task
Every 2 years	Switching the switch (es) on DF-2 cubicles <b>with an interrupting function</b> <ul style="list-style-type: none"> <li>• See “Switching of the switch(es) (DF-2 cubicles with an interrupting function)”.</li> </ul>
Every 2 years	Making the entire medium voltage switchgear voltage free <ul style="list-style-type: none"> <li>• See “Safety instructions – maintenance”</li> </ul>
Every 5 years	Removal of the roof panels (for cleaning purposes) <ul style="list-style-type: none"> <li>• See “Fitting the bus bars”</li> </ul>  <p>Ensure that the entire medium voltage switchgear is voltage free before removing the roof panels.</p>
Every 10 years	Replacing the fuses in DF-P cubicles <ul style="list-style-type: none"> <li>• See “Replacing the fuses (DF-P cubicles)”</li> </ul>

### 6.2.1 General checking actions

- Regularly carry out a thorough, general visual inspection.
- Check that the cables are still properly attached.

### 6.2.2 Cleaning the DF-2 cubicles

Contamination of the DF-2 cubicles can initially be limited by following the IEC recommendations concerning the installation area. See “Recommendations – installation area”.

#### 6.2.2.1 *Cleaning the outside*

- Read the safety instructions first. See “Safety instructions – maintenance”
- Clean the outside with a non-fluffy cloth and a non-corrosive cleaning agent.
- Rub the cleaned surfaces thoroughly dry.

#### 6.2.2.2 *Cleaning the inside*

The entire interior of the DF-2 cubicles must be kept free of dust, sediment and other contamination. This applies for isolators, sets of bus bar, apparatus and cable compartments.



A clean and dust-free interior increases the dielectric characteristics and limits the leakage current to a minimum.

- Remove the front panel. See “Erection”.
- Remove the door. See “Unpacking”.
- Clean the outside (also the cables) with a non-fluffy cloth and a non-corrosive cleaning agent.
- Thoroughly dry the cleaned surfaces to prevent fly rust, copper oxidation and corrosion of the fitting materials.
- Check all bolt-nut connections.
- Fit the front panel.
- Refit the door.

To be able to clean the inside of DF-2 cubicles with a circuit breaker properly, the circuit breaker must be temporarily removed from the cubicle. The method of disassembly varies according to the type of circuit breaker. See:

- “Sliding in and out the fix mounted circuit breaker (DF-D)”
- “Sliding in and out the withdrawable circuit breaker (DF-D-W)”

### 6.2.2.2.1 Sliding in and out the fix mounted circuit breaker (DF-D)

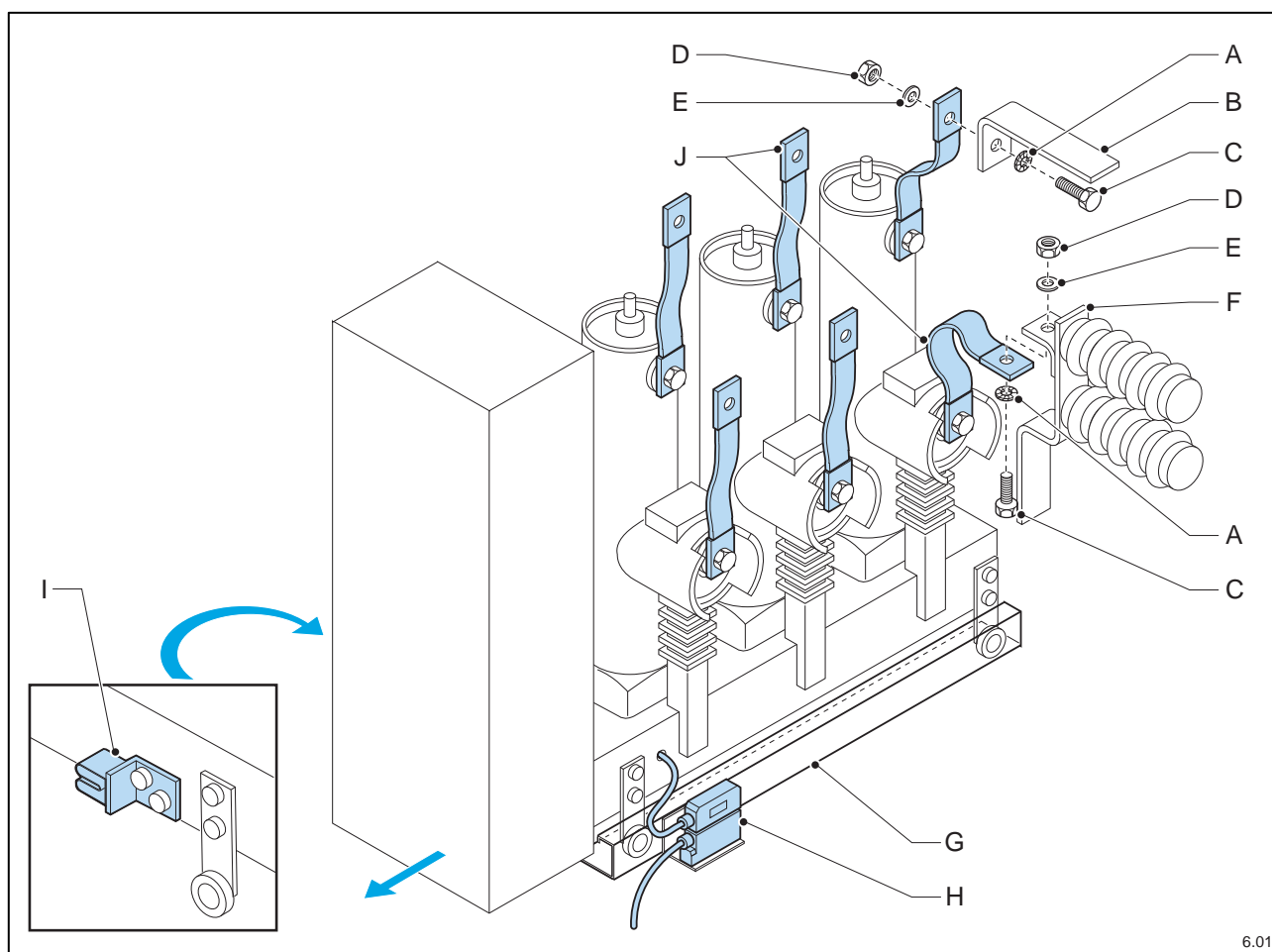

6.01

- Make the concerned cubicle voltage free. See “Safety instructions – maintenance”
- Remove the door. See “Unpacking”.
- Loosen the top connections of the circuit breaker:
  - Loosen the nuts (fig. 6.01D).
  - Remove the flat washers (fig. 6.01E).
  - Remove the lock washer (fig. 6.01A) and the hexagonal tap bolt (fig. 6.01C)
- Loosen the bottom connections of the circuit breaker:
  - Loosen the nuts (fig. 6.01D).
  - Remove the flat washers (fig. 6.01E).
  - Remove the lock washer (fig. 6.01A) and the hexagonal tap bolt (fig. 6.01C)



The flexible braid (fig. 6.01J) must stay on the circuit breaker.

- Disconnect any low voltage connector present on the circuit breaker (fig. 6.01H).
- Slide the circuit breaker out of the cable compartment.



Avoid damaging the earthing contact (fig. 6.01I) on the circuit breaker slide. Carefully slide out the circuit breaker.

Now the circuit breaker has been removed from the cubicle, the relay of the circuit breaker can be tested easily.

The following applies for sliding in the fix mounted circuit breaker:

- Place the circuit breaker with its rear wheels in the transport rails (fig. 6.01G).
- Slide the circuit breaker against the rear stop of the guides.
- Connect any low voltage connector present on the circuit breaker (fig. 6.01H).
- Loosen the bottom connections of the circuit breaker:
  - Place the connection against the connecting contact (fig. 6.01F).
  - Secure the whole assembly with the hexagonal tap bolt (fig. 6.01C), the lock washer (fig. 6.01A), the flat washer (fig. 6.01E) and the nut (fig. 6.01D).
- Fasten the top connections of the circuit breaker:
  - Place the connection against the connecting contact (fig. 6.01B).
  - Secure the whole assembly with the hexagonal tap bolt (fig. 6.01C), the lock washer (fig. 6.01A), the flat washer (fig. 6.01E) and the nut (fig. 6.01D).
- Fit the door of the cable compartment. See “Refitting the door”.
- Lock the door with a reliable padlock.
- Put the cubicle back into operation.

#### 6.2.2.2.2 Sliding in and out the withdrawable circuit breaker (DF-D-W)

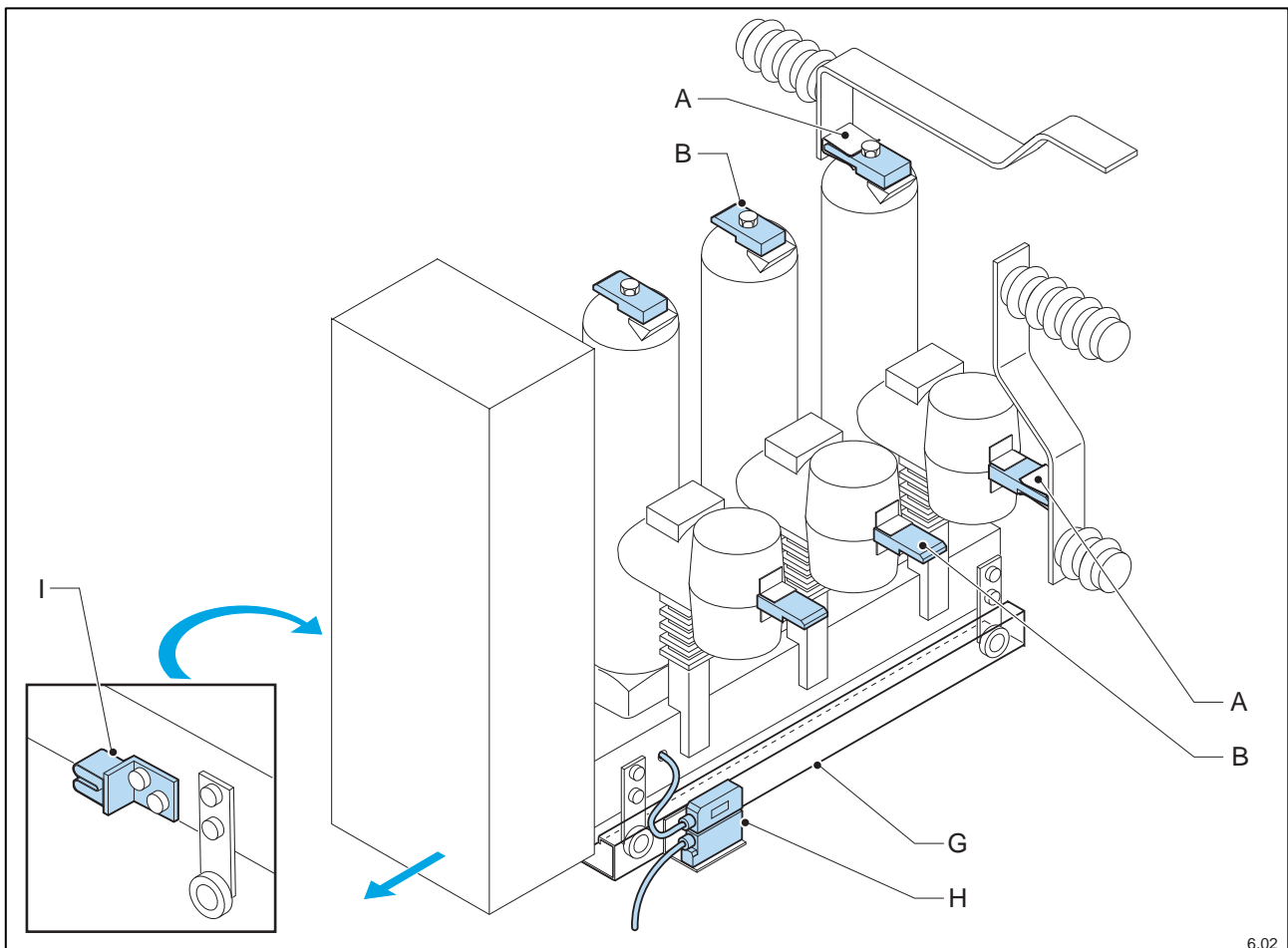

- Make the concerned cubicle voltage free. See “Safety instructions – maintenance”.

- Remove the door. See “Unpacking”.
- Disconnect any low voltage connector present on the circuit breaker (fig. 6.02H).
- Carefully pull the circuit breaker forwards so that the connections (fig. 6.02B) are freed of the sliding contacts (fig. 6.02A).
- Slide the circuit breaker out of the cable compartment.



Avoid damaging the earthing contact (fig. 6.01I) on the slide of the circuit breaker. Carefully slide out the circuit breaker.  
Transport the circuit breaker using the transport cradle supplied.

Now the circuit breaker has been removed from the cubicle, the relay of the circuit breaker can be tested easily.

The following applies for sliding in the withdrawable circuit breaker:

- Place the circuit breaker with its rear wheels in the transport rails (fig. 6.02G).
- Carefully push the circuit breaker backwards so that the connections (fig. 6.02B) are in the sliding contacts (fig. 6.02A).
- Slide the circuit breaker against the rear stop of the guides.
- Connect any low voltage connector present on the circuit breaker (fig. 6.02H).
- Fit the door of the cable compartment. See “Refitting the door”.
- Lock the door with a reliable padlock.
- Put the cubicle back into operation.
- Check the connections between the connections and the sliding contacts.

### 6.2.3 Lubricating the earthing knife and the damping blocks (if present)

On installation of the medium voltage switchgear, the earthing knife spoons and the damping blocks of the main earthing switch and (if present) the auxiliary earthing switch are given a coating of SGC lubricant. The periodic cleaning of the inside of the cubicles (especially the cleaning of the cable compartment) is the most suitable moment for cleaning and degreasing these components thoroughly to remove the dirt attracted by the grease.

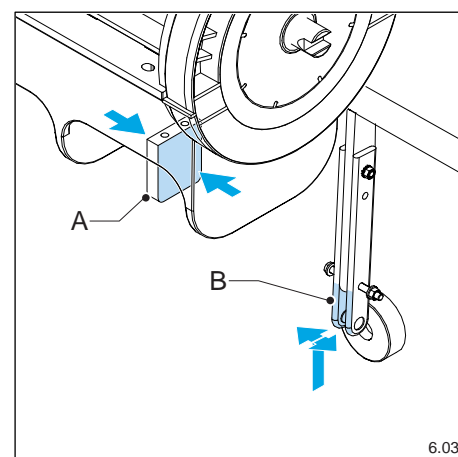

- Make the entire medium voltage switchgear voltage free. See “Safety instructions – maintenance”
- Remove the door. See “Unpacking”.
- Clean the earthing knife spoons (fig. 6.03B) and the damping blocks (fig. 6.03A).
- After cleaning these components, lubricate them again with an approx. 0.5 mm thick, evenly applied layer of the SGC grease supplied (order number: GR002002).



With DF-P cubicles not only the earthing knife spoons (fig. 6.04B) and damping blocks (fig. 6.04A) of the **main earthing switch**, as well as the earthing knife spoons (fig. 6.04C) and damping blocks (fig. 6.04D) of the **second earthing switch** (auxiliary earthing switch) has to be cleaned and then lubricated again.

- Fit the door of the cable compartment. See “Refitting the door”.
- Lock the door with a reliable padlock.
- Put the medium voltage switchgear back into operation.

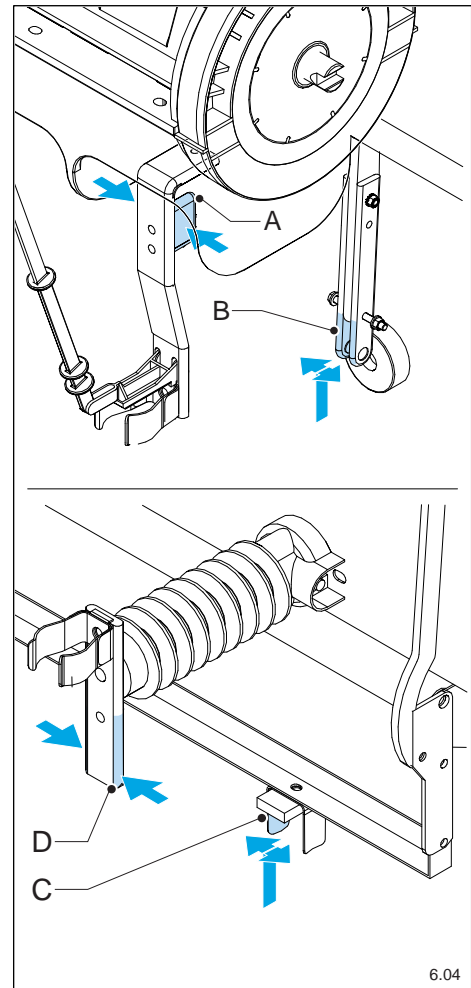

#### 6.2.4 Switching of the switch(es) (DF-2 cubicles with an interruption function)

Switches that are hardly ever used must be switched **at least every two years** to check the functioning of the mechanical components. See “Operation”.

#### 6.2.5 Replacing the fuse (DF-P cubicles)

The fuses in DF-P cubicles must be replaced **at least every 10 operating years**, or sooner if a repair task is necessary in this frame (for example after one of the fuses was tripped).



Always replace **all three** HOV fuses at the same time, even when only one is defective.

- Make the entire medium voltage switchgear voltage free. See “Safety instructions – maintenance”
- Remove the door. See “Unpacking”.

- Remove the three fuses, starting with the front fuse:
  - Push the fuse (fig. 6.05C) at the top out of the spring clip (fig. 6.05A).
  - Take the fuse out of the spring clip at the bottom (fig. 6.05B).
- Fit the new fuses. Start at the back of the cubicle and work methodically towards the door opening:



Ensure that the hitting bolts (fig. 6.05E) are at the top. The indicator on the fuse (fig. 6.05D) should point upwards.

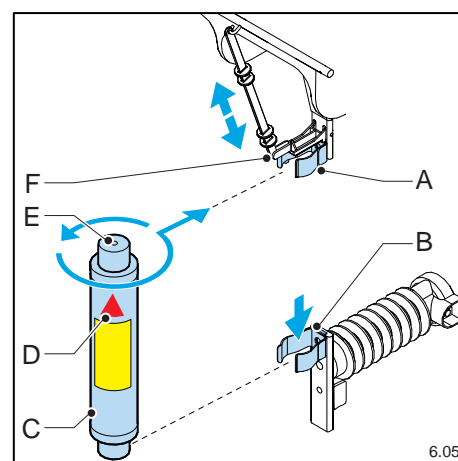

- Fit the fuse in the bottom spring clip (fig. 6.05B).
- With a rotating movement, push the fuse into the top spring clip (fig. 6.05A). This prevents damage to the bending of the spring clip.
- Manually check the tripping mechanism: the levers (fig. 6.05F) should not be trapped or show signs of defect.
- Fit the door of the cable compartment. See “Refitting the door”.
- Lock the door with a reliable padlock.
- Put the medium voltage switchgear back into operation.

### 6.2.6 Emptying the oil tray (DF-T cubicles with oil-filled transformers)

- Regularly check the level of the oil in the tray.
- When necessary, dispose off the oil in an environmentally friendly way.





## 7 CONNECTION DIAGRAMS

### 7.1 Numbering of terminals DF-A, DF-P en DF-D: part 1

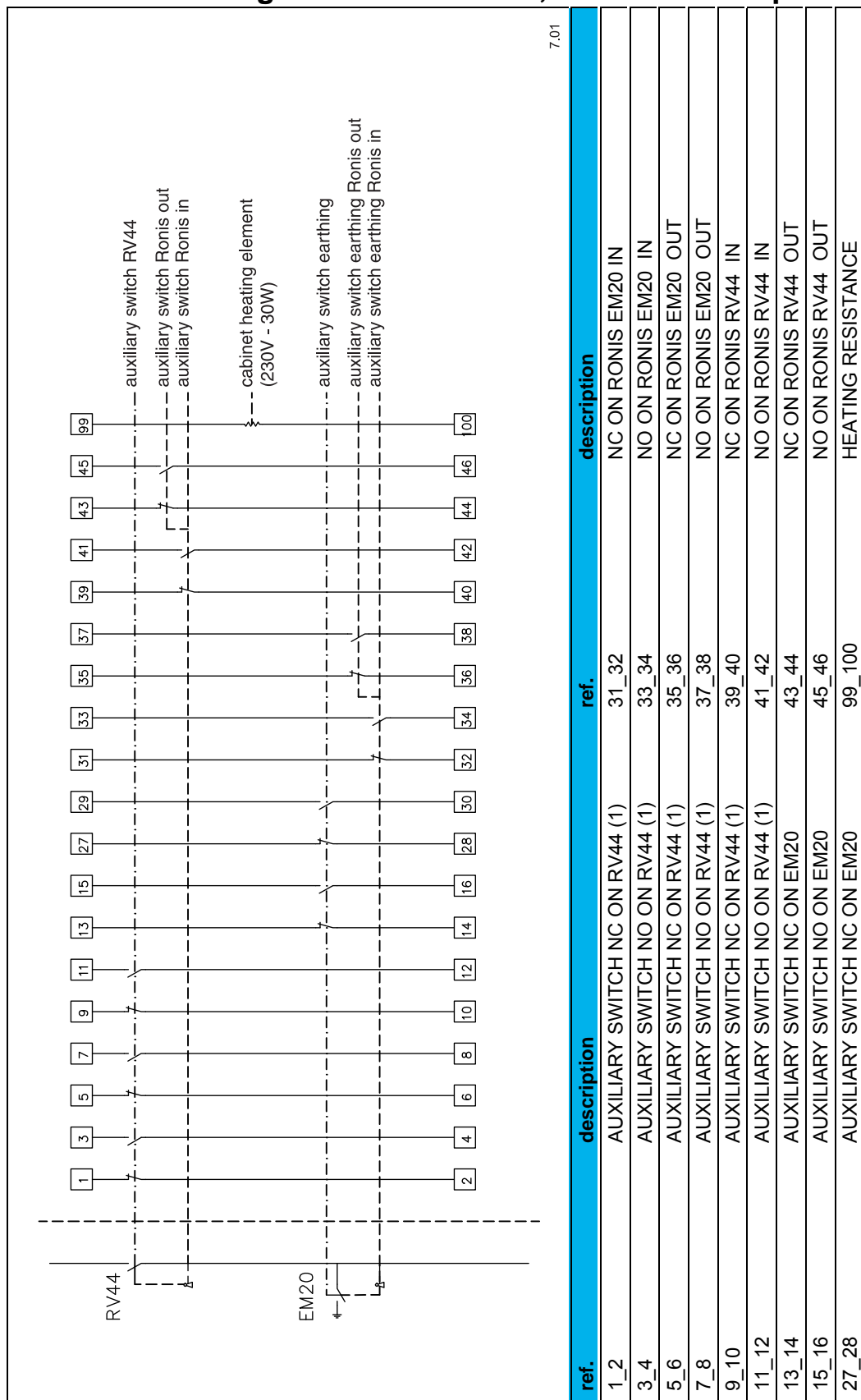

## 7.2 Numbering of terminals DF-A, DF-P en DF-D: part 2

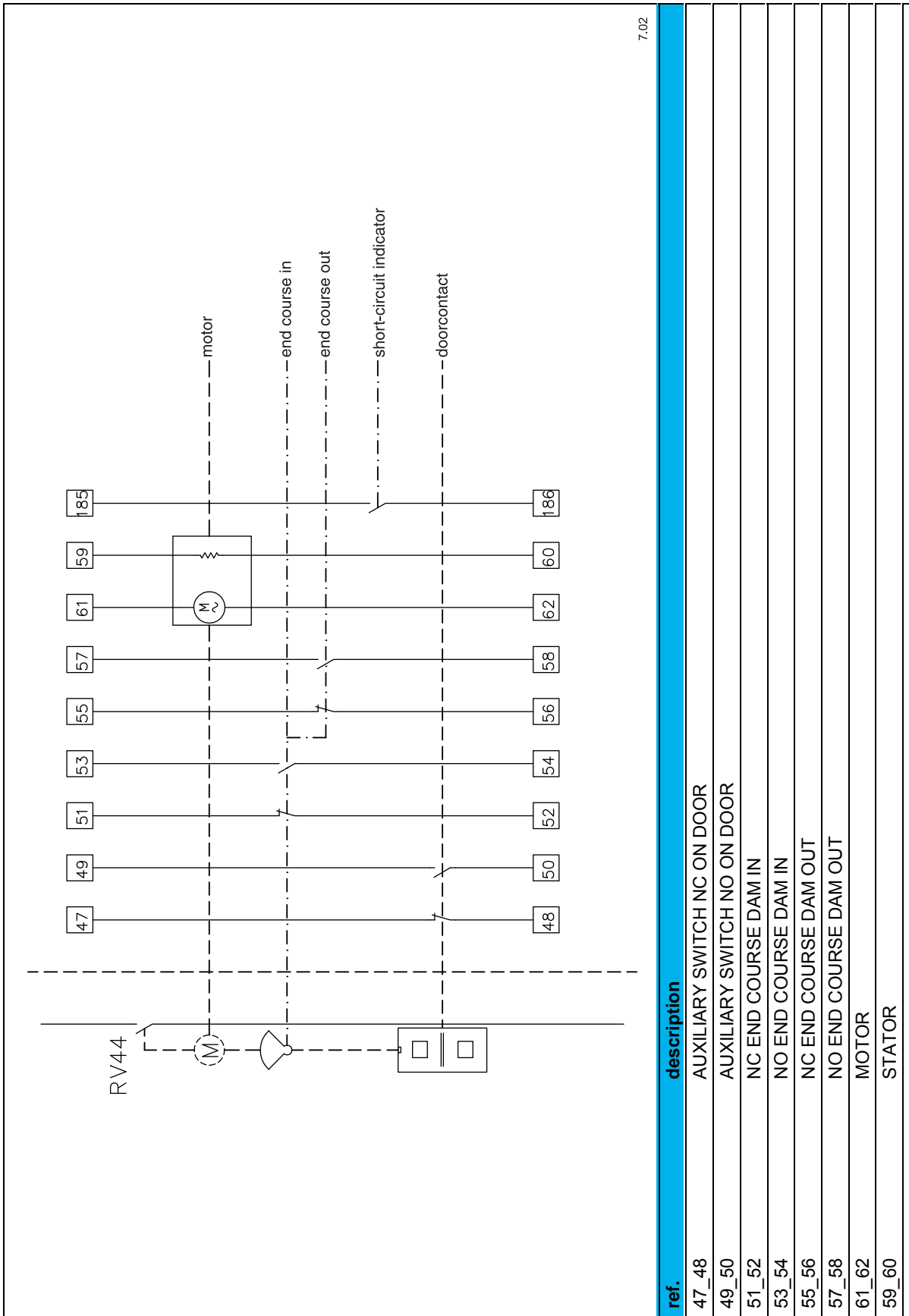

7.02

### 7.3 Numbering of terminals DF-P: part 3

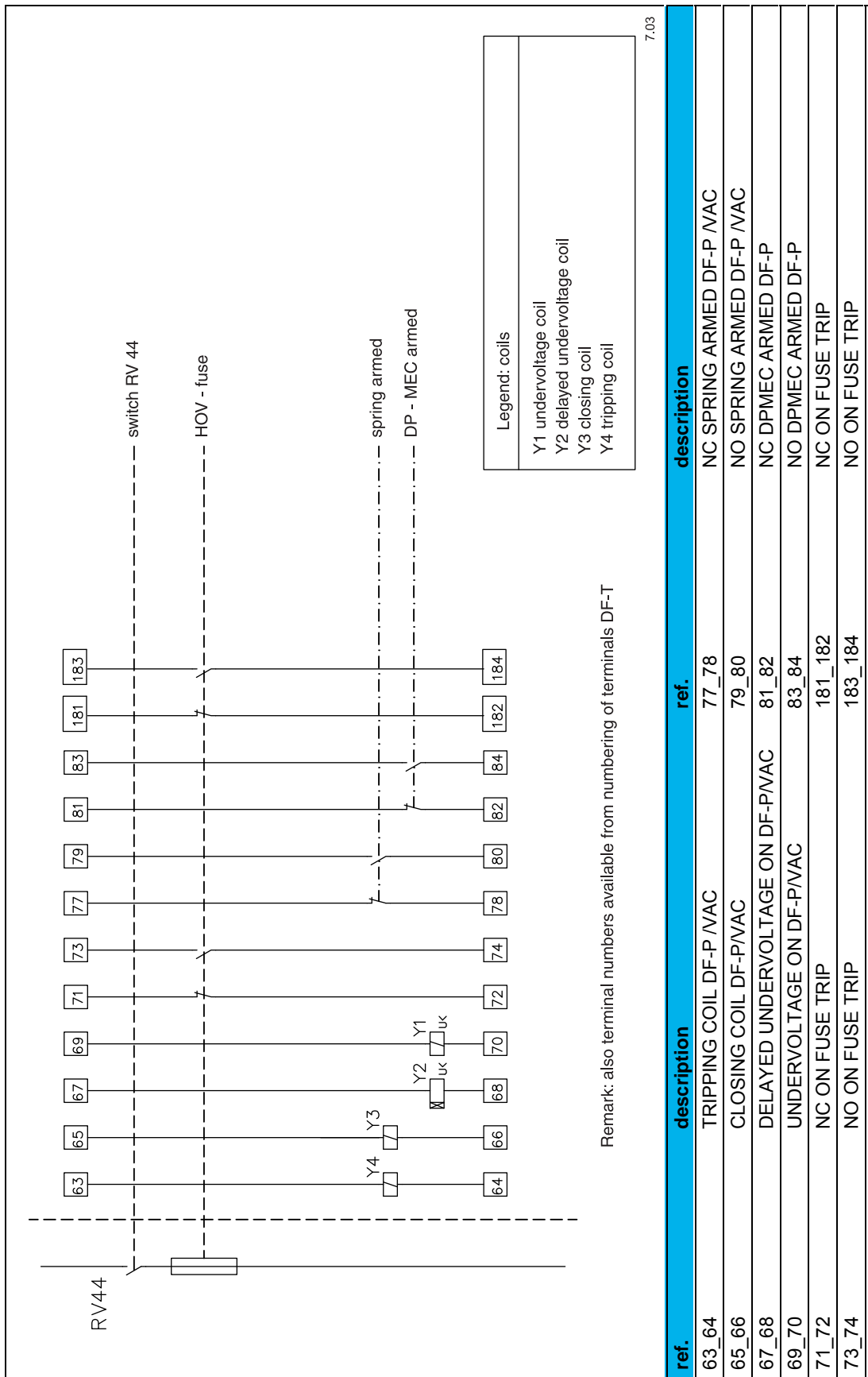

## 7.4 Numbering of terminals DF-D: part 3

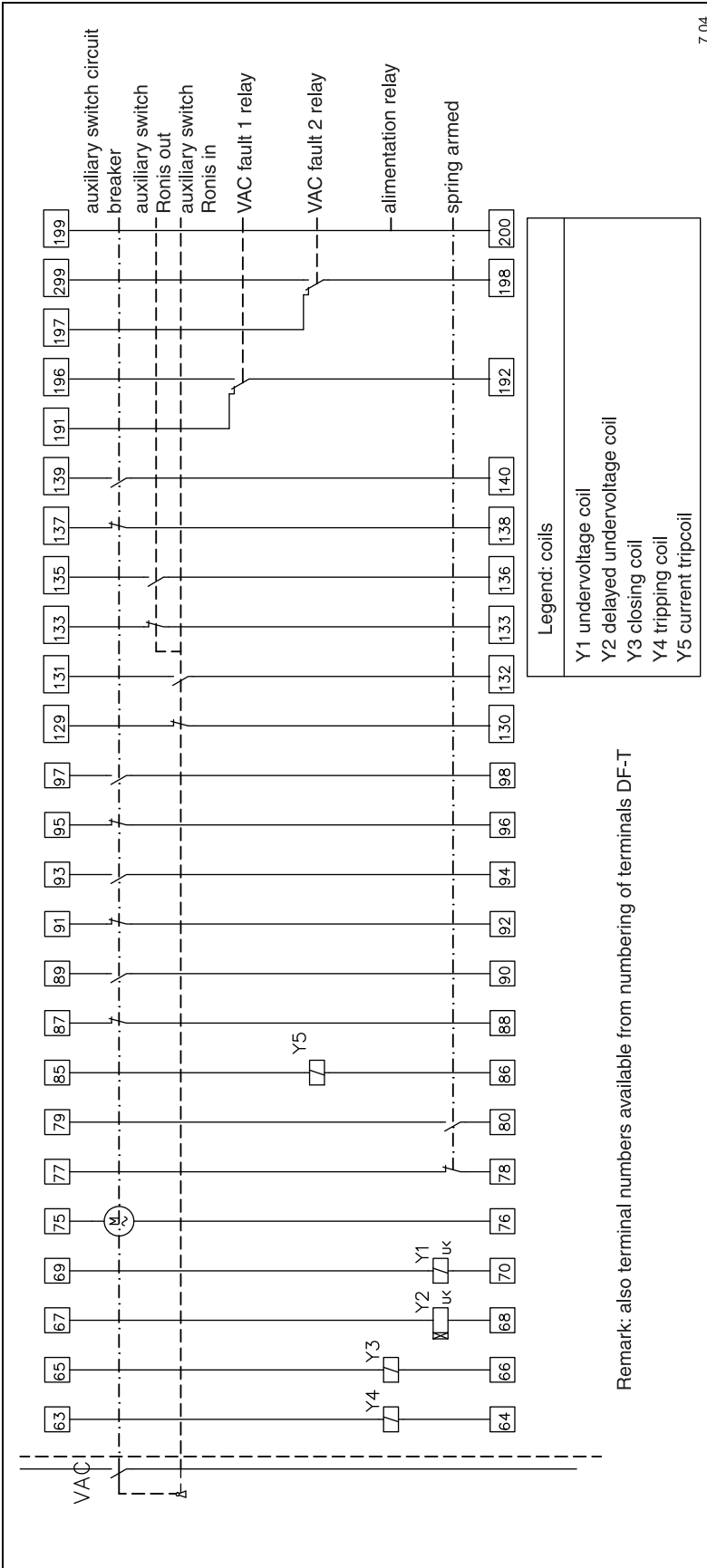

7.04

Remark: also terminal numbers available from numbering of terminals DF-T

ref.	description	ref.	description
63_64	TRIPPING COIL DF-P /VAC	95_96	AUXILIARY SWITCH NC ON VAC
65_66	CLOSING COIL DF-P/VAC	97_98	AUXILIARY SWITCH NO ON VAC
67_68	DELAYED UNDERVOLTAGE ON DF-P/VAC	129_130	NC ON RONIS VAC IN
69_70	UNDERVOLTAGE ON DF-P/VAC	131_132	NO ON RONIS VAC IN
75_76	MOTOR VAC	133_134	NC ON RONIS VAC OUT
77_78	NC SPRING ARMED DF-P /VAC	135_136	NO ON RONIS VAC OUT
79_80	NO SPRING ARMED DF-P /VAC	137_138	AUXILIARY SWITCH NC ON VAC
85_86	CURRENT TRIPCOIL VAC	139_140	AUXILIARY SWITCH NO ON VAC
87_88	AUXILIARY SWITCH NC ON VAC	191_192_196	CHANGE OVER CONTACT VAC FAULT 1 RELAY
89_90	AUXILIARY SWITCH NO ON VAC	197_198_299	CHANGE OVER CONTACT VAC FAULT RELAY 2
91_92	AUXILIARY SWITCH NC ON VAC	199_200	ALIMENTATION RELAY VAC (RP600-PS421-)

## 7.5 Numbering of terminals DF-A with motor Sibelgaz

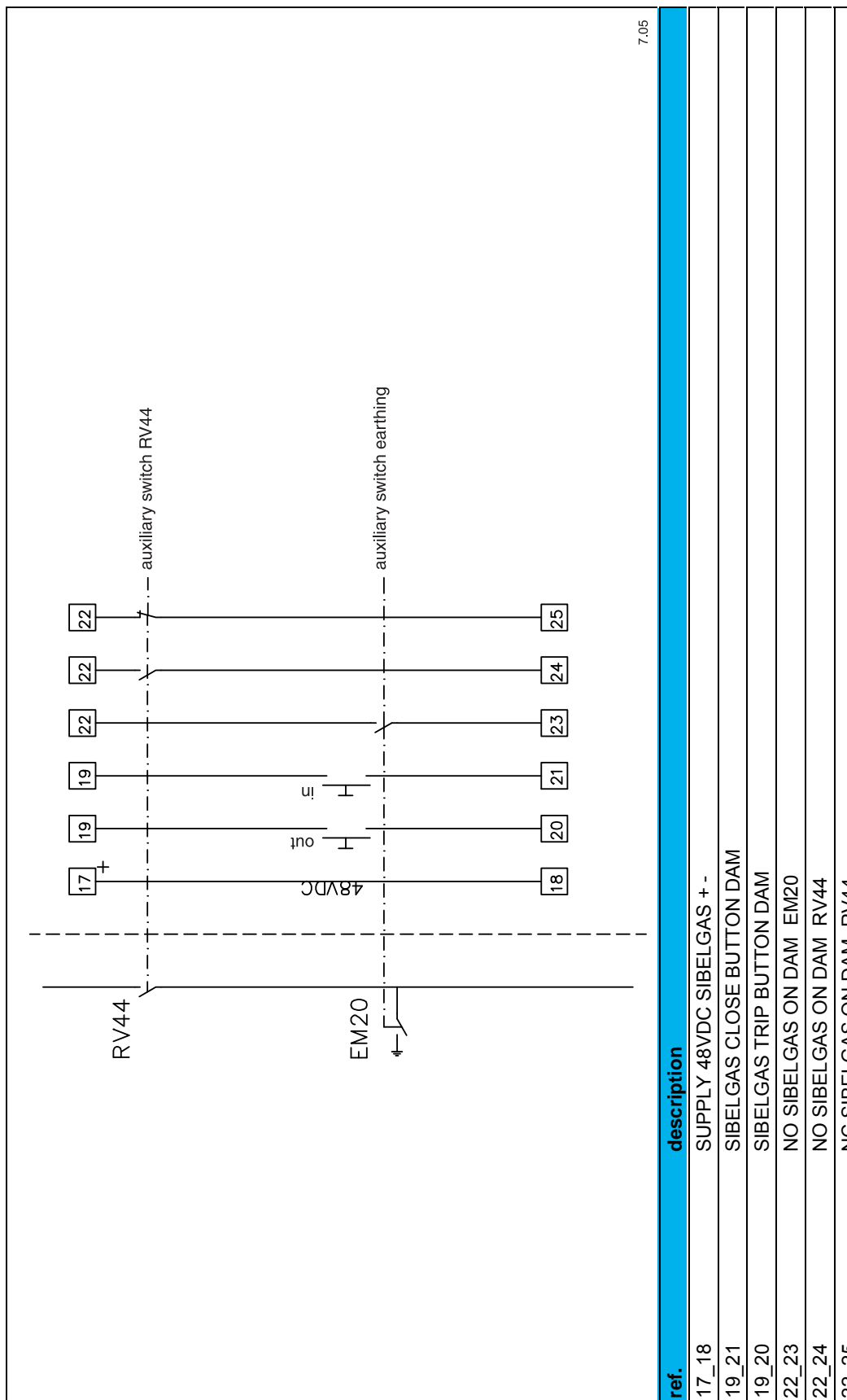

7.05

## 7.6 Numbering of terminals CT / VT

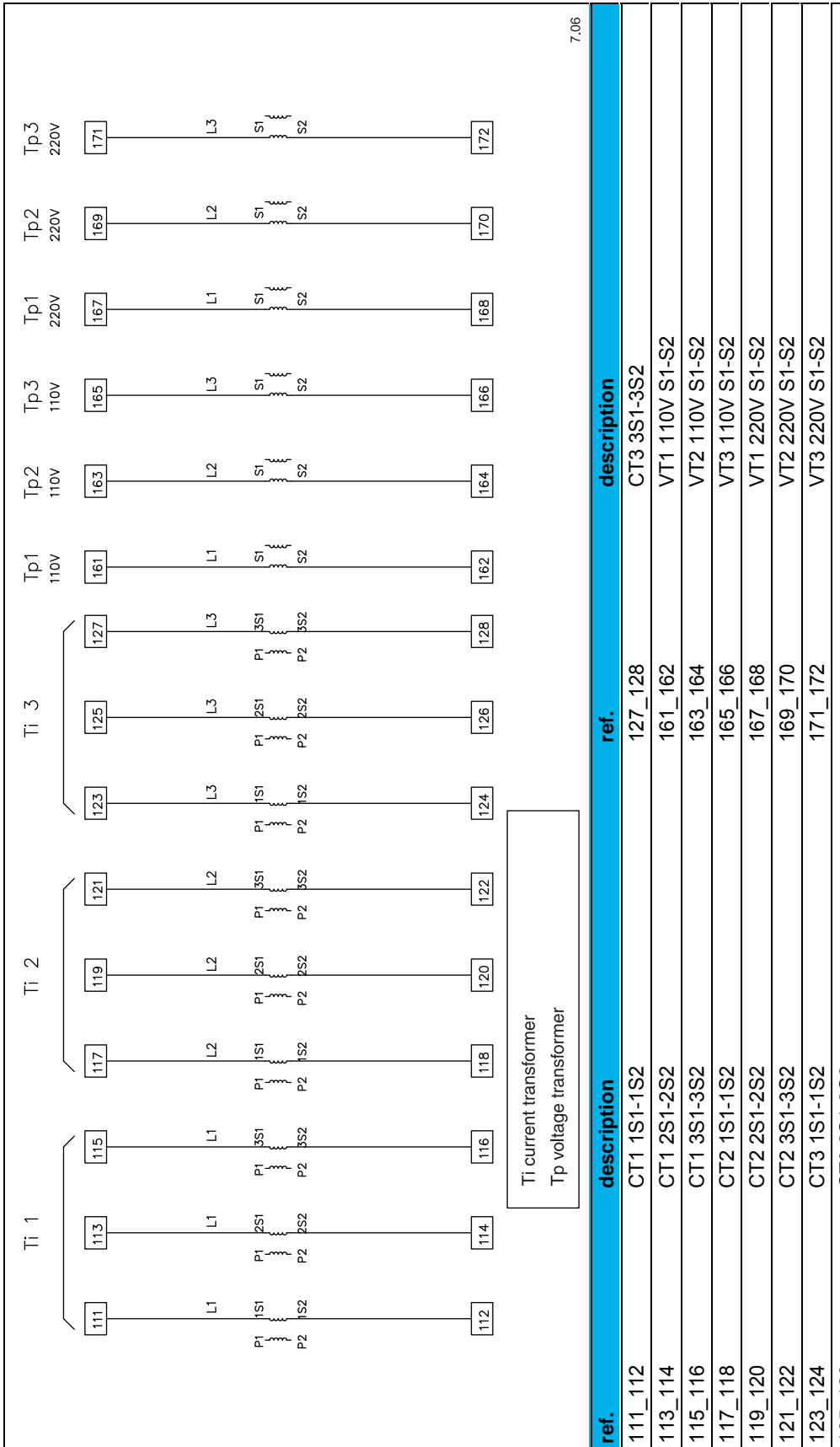

7.06

## 7.7 Numbering of terminals DF-T:

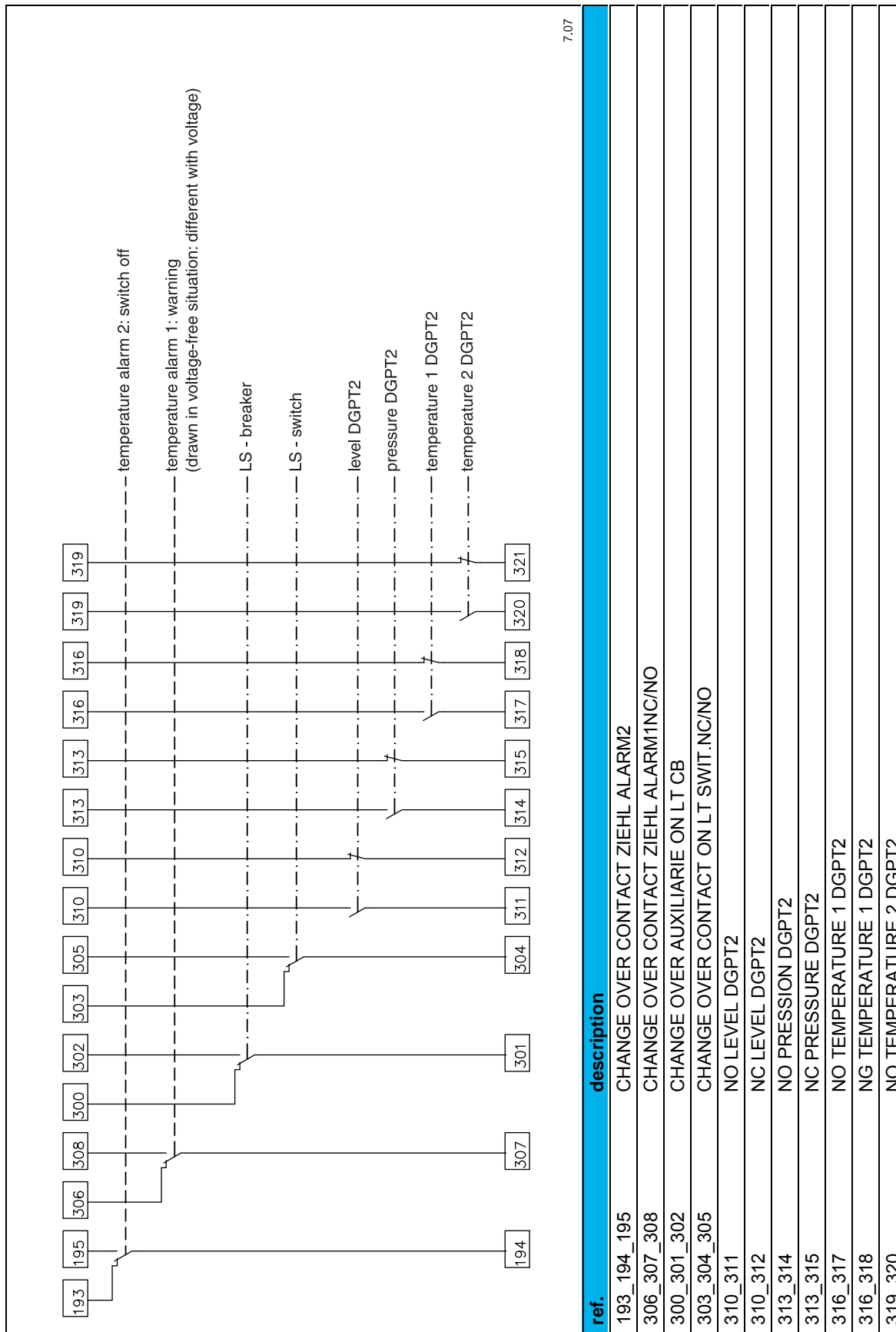

## 7.8 Numbering of terminals general

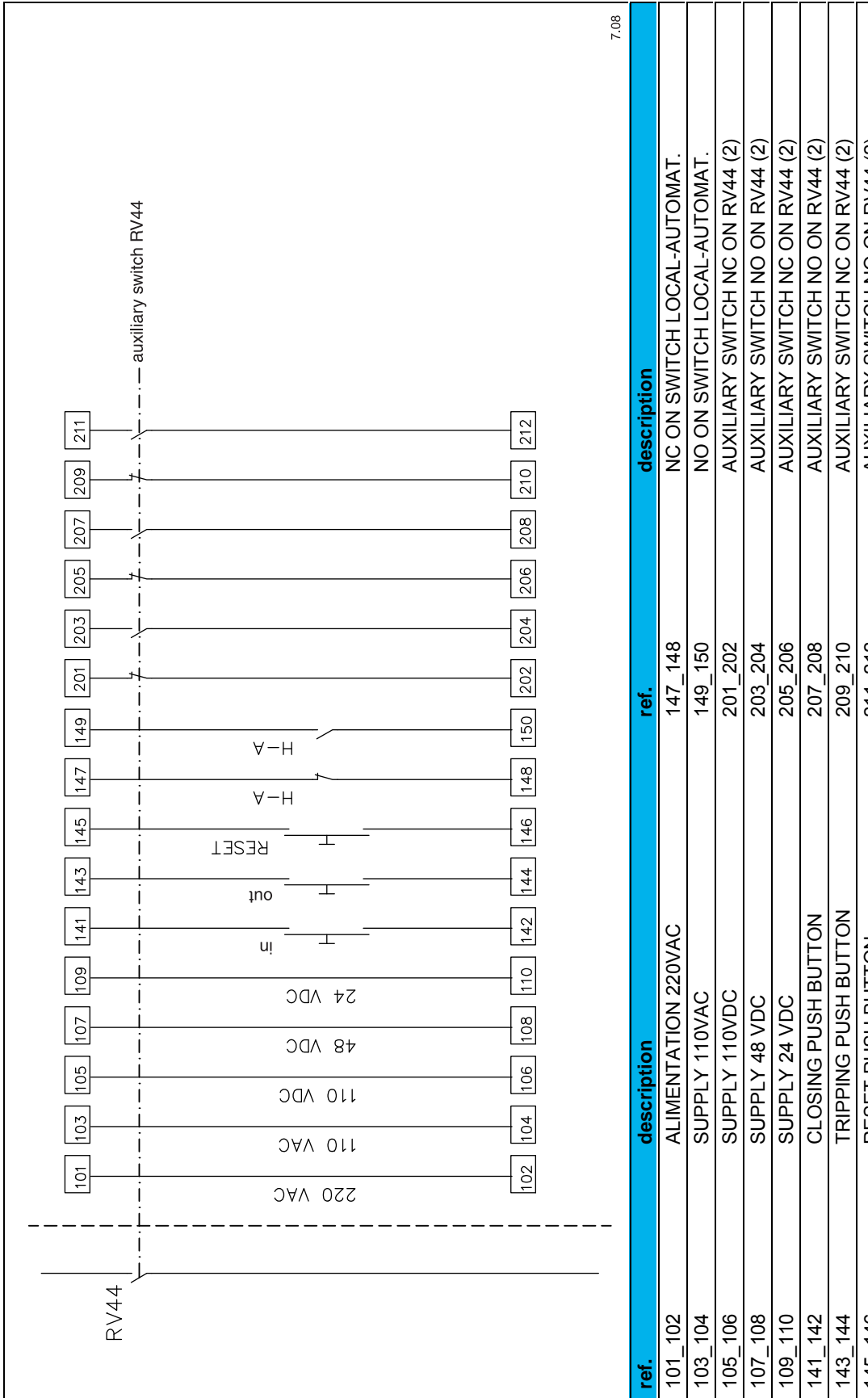

7.08



## 8 DF-2 CUBICLES AND THE ENVIRONMENT

### 8.1 Packing material



The packing material mainly consists of:

- (Untreated) wood
- Plastic straps
- Plastic film

- Contact the local public cleaning department for the details of recycling or an environmentally friendly way of processing the packing materials.
- Tender the packing material as instructed (separated).



For Belgium: Euro pallets must, after installation of the cubicles, be returned to SwitchGear Company nv.

### 8.2 Disposal of the cubicles

With a view to the re-use of electrical components, the RV 44 load break switches filled with SF<sub>6</sub>-gas (sulphur hexafluoride) could be returned to SwitchGear Company nv at the end of their life or when damaged.

On consultation, complete DF-2 cubicles can also be returned. If this is not possible, the cubicles must be processed in an environmentally friendly way.

- Contact the local public cleansing department and tender the material in the prescribed manner (separated).



## 9 MOUNTING OF OPTIONS

For DF-2 cells with an interrupting function various drive mechanisms are available. For a complete overview of the scope for each cell type, as well as the functioning of the various drive mechanisms, see the Technical Brochure (order number: AG601101). Depending on the drive mechanism present, one or more of the following options (possibly combined) can be mounted:

- auxiliary contact(s) on the shaft of the load break switch
- auxiliary contact(s) on the shaft of the earth switch
- auxiliary contact(s) for indicating the position of the key lock
- auxiliary contact(s) for indicating the tripping of the fuse
- auxiliary contact(s) for the DP-A or DP-A-M reinforced
- key lock(s) on the shaft of the load isolation switch
- key lock(s) on the shaft of the earth switch
- mechanical indication of the tripping of the fuse
- under-voltage release(s) (with or without minutia)
- shunt-trip release(s)



For a complete overview of the possible options for each drive mechanism, see the Technical Brochure (order number: AG601101). Separate mounting instructions are delivered with the options.

### Available mounting instructions:

description	item numbers
DA – Auxiliary contact(s) on the load break switch/earth switch	IVS-13-007-01-100
DA-M – Auxiliary contacts on the earth switch	IVS-13-007-01-101
DA-M – Auxiliary contacts for the key lock on the load break switch/earth switch	IVS-13-007-01-102
DA-K – Auxiliary contact(s) on the load break switch	IVS-13-007-01-103
DA-K-M – Auxiliary contact(s) on the load break switch	IVS-13-007-01-104
DA-EDN-D – Auxiliary contact(s) on the load break switch	IVS-13-007-01-105
DP – Auxiliary contact(s) on the load break switch	IVS-13-007-01-106
DP – Auxiliary contact for indicating the state of the fuse	IVS-13-007-01-107
DP-M – Auxiliary contact for indicating the state of the fuse	IVS-13-007-01-108
DA – Key locks on the load break switch/earth switch	IVS-13-007-01-200
DA-M – Key locks on the load break switch/earth switch	IVS-13-007-01-201
DP – Key locks on the earth switch	IVS-13-007-01-202
DP – Key locks on the load break switch	IVS-13-007-01-203
DP, DP-M, DP-A, DP-A-M – Mounting of the shunt-trip release	IVS-13-007-01-300
DP – Mounting of an under-voltage release, delayed with minutia	IVS-13-007-01-301

## 9.1 Auxiliary contacts

Auxiliary contacts can be mounted at various places on the drive mechanism and always have an indicating function:

- auxiliary contacts on the shaft of the load break switch indicate the position of the load break switch
- auxiliary contacts on the shaft of the earth switch indicate the position of the earth switch
- auxiliary contacts for key locks indicate the position of the key lock
- auxiliary contacts for fuses indicate the status of the fuse (tripped – not tripped)
- auxiliary contacts for DP-A or DP-A-M reinforced, indicate the status of this position

### 9.1.1 Preparation for mounting

The following preparations must always be taken **before** you start mounting one or more auxiliary contacts:

- Make the entire medium voltage board voltage free.

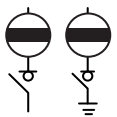

Open the particular cell as well as the load isolation and the earth switches (if present).

- Dismount the front panel:
  - Loosen the four hexagonal tap bolts (fig. 10.01C)
  - Remove the four washers (fig. 10.01B).
  - Remove the front panel (fig. 10.01A).

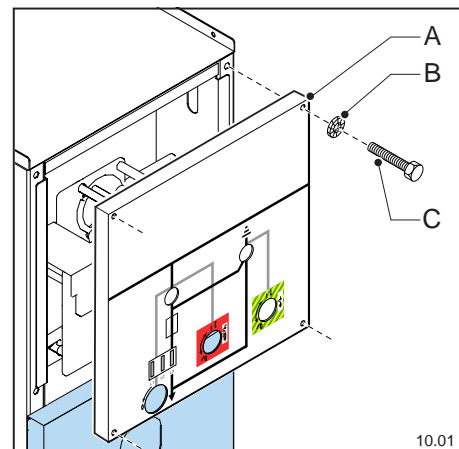

### 9.1.2 Mounting of auxiliary contacts - general

Special mounting kits are available for the mounting of auxiliary contacts.

The composition of these mounting kits and thus the method and/or order of mounting varies depending on factors such as:

- type of drive mechanism
- function of the auxiliary contact
- number of extra auxiliary contacts to be mounted

**i** The table with the accompanying figure shows the composition of a **standard single auxiliary contact**. This assembly is always applicable, regardless of the function of the auxiliary contact and the type of drive mechanism. For further information and detailed mounting instructions **for each specific mounting kit**, see “Mounting of auxiliary contacts – specific (for each drive mechanism)”

order number	description	number	pos. no.
OP401100	auxiliary contact – shaft, straight model, pre-mounted on carrier plate	1	fig. 10.02A
GR041604	DIN 6798A Ø M4 lock washer	2	fig. 10.02B
GR040909	DIN 912 M4x6 cylindrical screw	2	fig. 10.02C

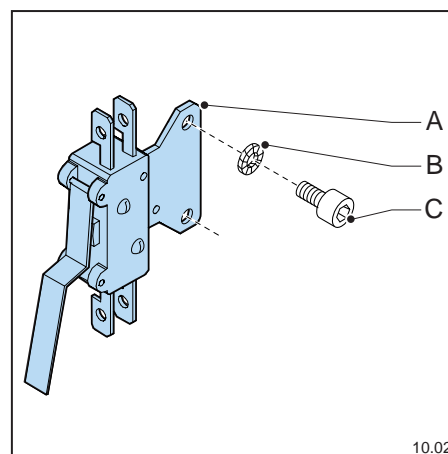

### 9.1.3 Final checking and commissioning

The following actions must always be carried out **after** mounting one or more auxiliary contacts:

- Check that the fitting materials are properly attached.
- Measure the auxiliary contacts – in the closed as well as open position – using a multimeter.
- Connect the auxiliary contacts electronically using the plug connections.
- Mount the front panel.
- Put the particular cell into operation: earth switch (if present) OPEN, load break switch CLOSED.
- Put the medium voltage board back into operation.

### 9.1.4 Mounting of auxiliary contacts – specific (for each drive mechanism)

#### 9.1.4.1 DP – Auxiliary contact(s) on the load break switch

For mounting auxiliary contacts on the load break switch of the DP-drive mechanism, several mounting kits are available.

The composition of these mounting kits vary, depending on factors like:

- number of contacts ordered
- version (left or right-handed) of the auxiliary contacts
- type of auxiliary contact (shaft or wheel)

In all cases, the auxiliary contacts have already been pre-mounted on the carrier plate.

### 9.1.4.1.1 Available auxiliary contacts

order number	description
OP401001	1x auxiliary contact – wheel, left-handed model, on carrier plate for one auxiliary contact
OP401011	1x auxiliary contact – wheel, left-handed model, on carrier plate for two auxiliary contacts
OP401100	1x auxiliary contact – shaft, right-handed model, on carrier plate for one auxiliary contact
OP401101	1x auxiliary contact – shaft, left-handed model, on carrier plate for one auxiliary contact
OP401110	1x auxiliary contact – shaft, right-handed model, on carrier plate for two auxiliary contacts
OP402010	2x auxiliary contact – wheel, right-handed model, on carrier plate for two auxiliary contacts
OP402011	2x auxiliary contact – wheel, left-handed model, on carrier plate for two auxiliary contacts
OP402110	2x auxiliary contact – shaft, right-handed model, on carrier plate for two auxiliary contacts
OP402111	2x auxiliary contact – shaft, left-handed model, on carrier plate for two auxiliary contacts
OP403021	3x auxiliary contact – wheel, left-handed model, on carrier plate for three auxiliary contacts
OP403121	3x auxiliary contact – shaft, left-handed model, on carrier plate for three auxiliary contacts

- See following table.

order number	description	number	pos. no.
OP401011	1x auxiliary contact – wheel, left-handed model, on carrier plate for two auxiliary contacts	1	fig. 10.15A
GR041604	DIN 6798A Ø M4 lock washer	2	fig. 10.15B
GR040909	DIN 912 M4x6 cylindrical screw	2	fig. 10.15C

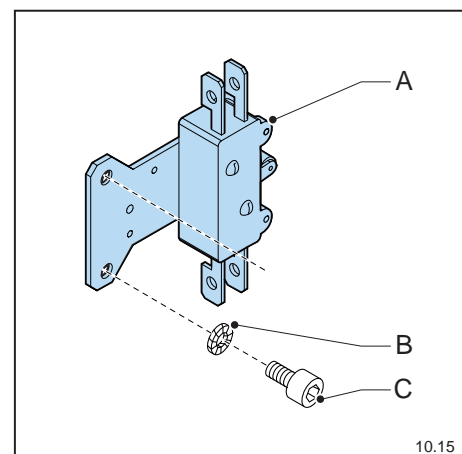

### 9.1.4.1.2 Mounting instructions



For preparing and finishing work, see “Preparation for mounting” and “Final check and commissioning” respectively.

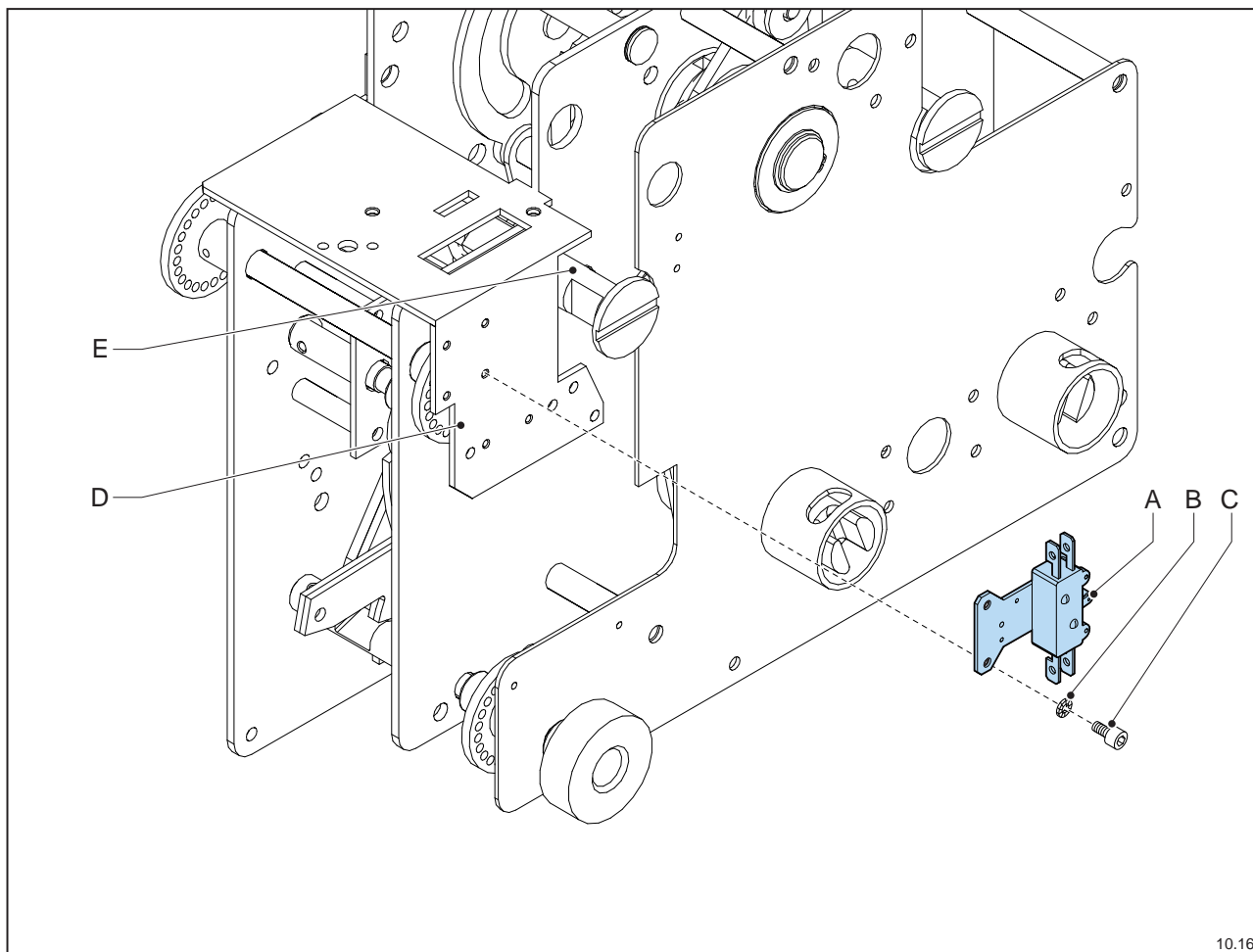

- Mount the carrier plate with the auxiliary contacts (fig. 10.16A) using the cylindrical screws (fig. 10.16C) and the lock washers (fig. 10.16B) on the support plate (fig. 10.16D) for the shunt-trip release. The support plate is provided with holes for this.



Avoid damaging the auxiliary contact by the indicator (fig. 10.16E). Ensure that the wheel of the auxiliary contact is pointing down.

#### 9.1.4.2 DA-K – Auxiliary contact(s) on the load break switch

For mounting auxiliary contacts on the load break switch of the DA-K-drive mechanism, several mounting kits are available.

The composition of these mounting kits vary, depending on factors such as:

- number of contacts ordered
- version (left or right-handed) of the auxiliary contacts
- type of auxiliary contact (shaft or wheel)

In all cases, the auxiliary contacts have already been pre-mounted on the carrier plate.

### 9.1.4.2.1 Available auxiliary contacts

order number	description
OP401001	1x auxiliary contact – wheel, left-handed model, on carrier plate for one auxiliary contact
OP401011	1x auxiliary contact – wheel, left-handed model, on carrier plate for two auxiliary contacts
OP401100	1x auxiliary contact – shaft, right-handed model, on carrier plate for one auxiliary contact
OP401101	1x auxiliary contact – shaft, left-handed model, on carrier plate for one auxiliary contact
OP401110	1x auxiliary contact – shaft, right-handed model, on carrier plate for two auxiliary contacts
OP402010	2x auxiliary contact – wheel, right-handed model, on carrier plate for two auxiliary contacts
OP402011	2x auxiliary contact – wheel, left-handed model, on carrier plate for two auxiliary contacts
OP402110	2x auxiliary contact – shaft, right-handed model, on carrier plate for two auxiliary contacts
OP402111	2x auxiliary contact – shaft, left-handed model, on carrier plate for two auxiliary contacts
OP403021	3x auxiliary contact – wheel, left-handed model, on carrier plate for three auxiliary contacts
OP403121	3x auxiliary contact – shaft, left-handed model, on carrier plate for three auxiliary contacts

- See following table.

order number	description	number	pos. no.
OP402011	2x auxiliary contact – wheel, left-handed model, pre-mounted on carrier plate	1	fig. 10.11A
GR041604	DIN 6798A Ø M4 lock washer	2	fig. 10.11B
GR040909	DIN 912 M4x6 cylindrical screw	2	fig. 10.11C

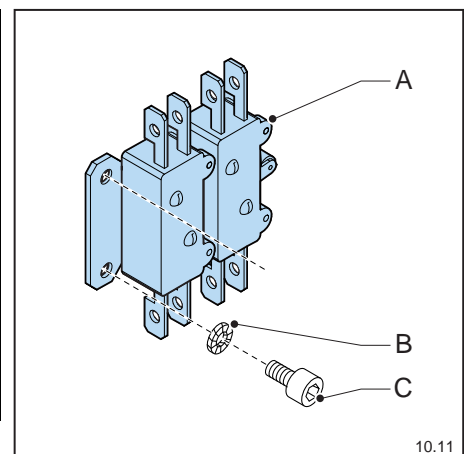

### 9.1.4.2.2 Mounting instructions



For preparing and finishing work, see “Preparation for mounting” and “Final check and commissioning” respectively.



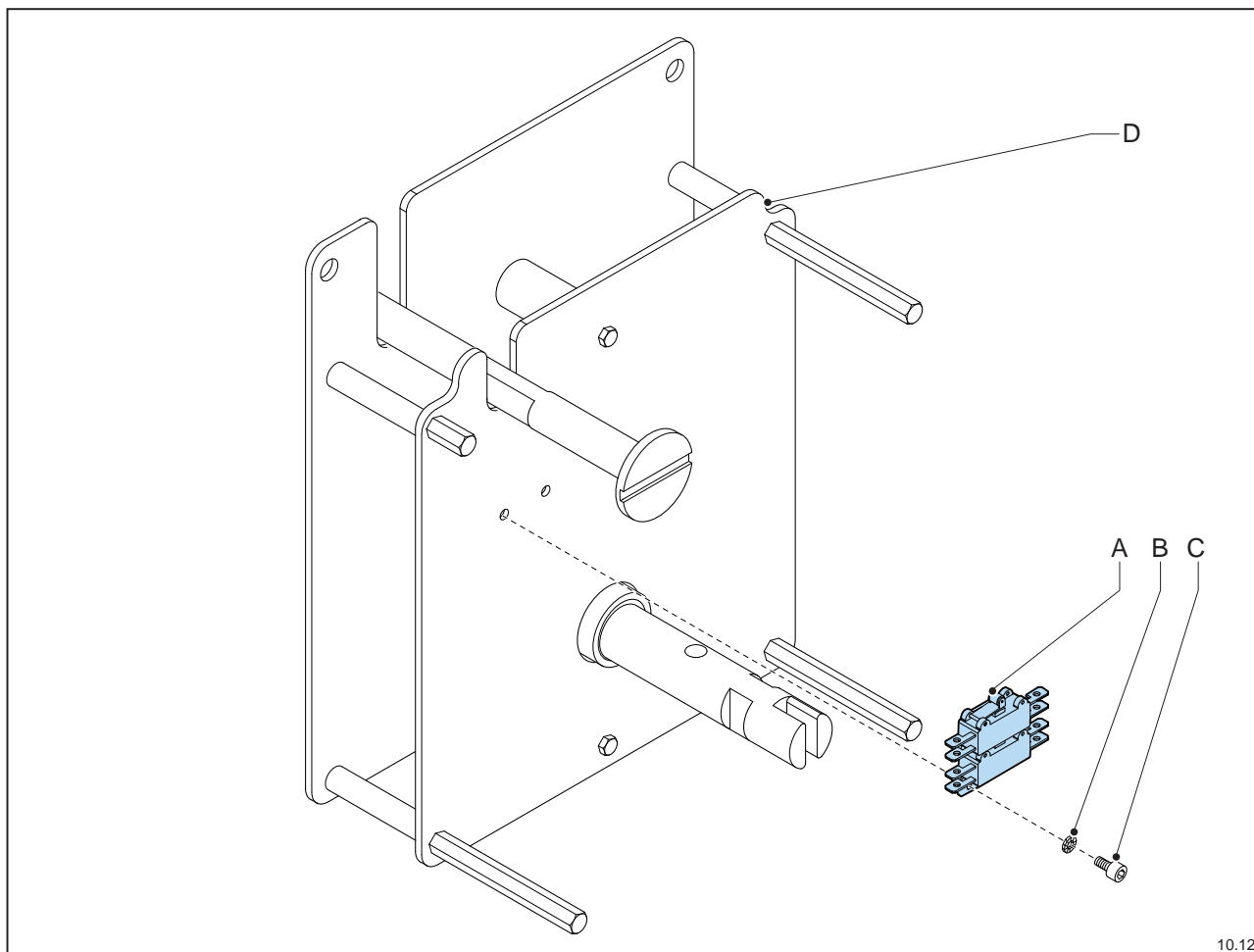

- Mount the carrier plate with the auxiliary contacts (fig. 10.12A) using the cylindrical screws (fig. 10.12C) and the lock washers (fig. 10.12B) on the front plate (fig. 10.12D). The front plate is provided with holes for this.

#### **9.1.4.3 DA-K-M – Auxiliary contact(s) on the load break switch**

For mounting auxiliary contacts on the load break switch of the DA-K-M-drive mechanism, several mounting kits are available.

The composition of these mounting kits vary, depending on factors such as:

- number of contacts ordered
- version (left or right-handed) of the auxiliary contacts
- type of auxiliary contact (shaft or wheel)

In all cases, the auxiliary contacts have already been pre-mounted on the carrier plate.

### 9.1.4.3.1 Available auxiliary contacts

order number	description
OP401001	1x auxiliary contact – wheel, left-handed model, on carrier plate for one auxiliary contact
OP401011	1x auxiliary contact – wheel, left-handed model, on carrier plate for two auxiliary contacts
OP401100	1x auxiliary contact – shaft, right-handed model, on carrier plate for one auxiliary contact
OP401101	1x auxiliary contact – shaft, left-handed model, on carrier plate for one auxiliary contact
OP401110	1x auxiliary contact – shaft, right-handed model, on carrier plate for two auxiliary contacts
OP402010	2x auxiliary contact – wheel, right-handed model, on carrier plate for two auxiliary contacts
OP402011	2x auxiliary contact – wheel, left-handed model, on carrier plate for two auxiliary contacts
OP402110	2x auxiliary contact – shaft, right-handed model, on carrier plate for two auxiliary contacts
OP402111	2x auxiliary contact – shaft, left-handed model, on carrier plate for two auxiliary contacts
OP403021	3x auxiliary contact – wheel, left-handed model, on carrier plate for three auxiliary contacts
OP403121	3x auxiliary contact – shaft, left-handed model, on carrier plate for three auxiliary contacts

- See following table.

order number	description	number	pos. no.
OP403121	3x auxiliary contact – shaft, left-handed model, pre-mounted on carrier plate	1	fig. 10.09A
GR041604	DIN 6798A Ø M4 lock washer	2	fig. 10.09B
GR040909	DIN 912 M4x6 cylindrical screw	2	fig. 10.09C

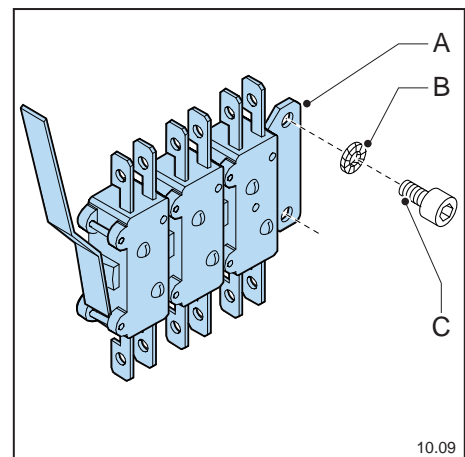

### 9.1.4.3.2 Mounting instructions



For preparing and finishing work, see “Preparation for mounting” and “Final check and commissioning” respectively.

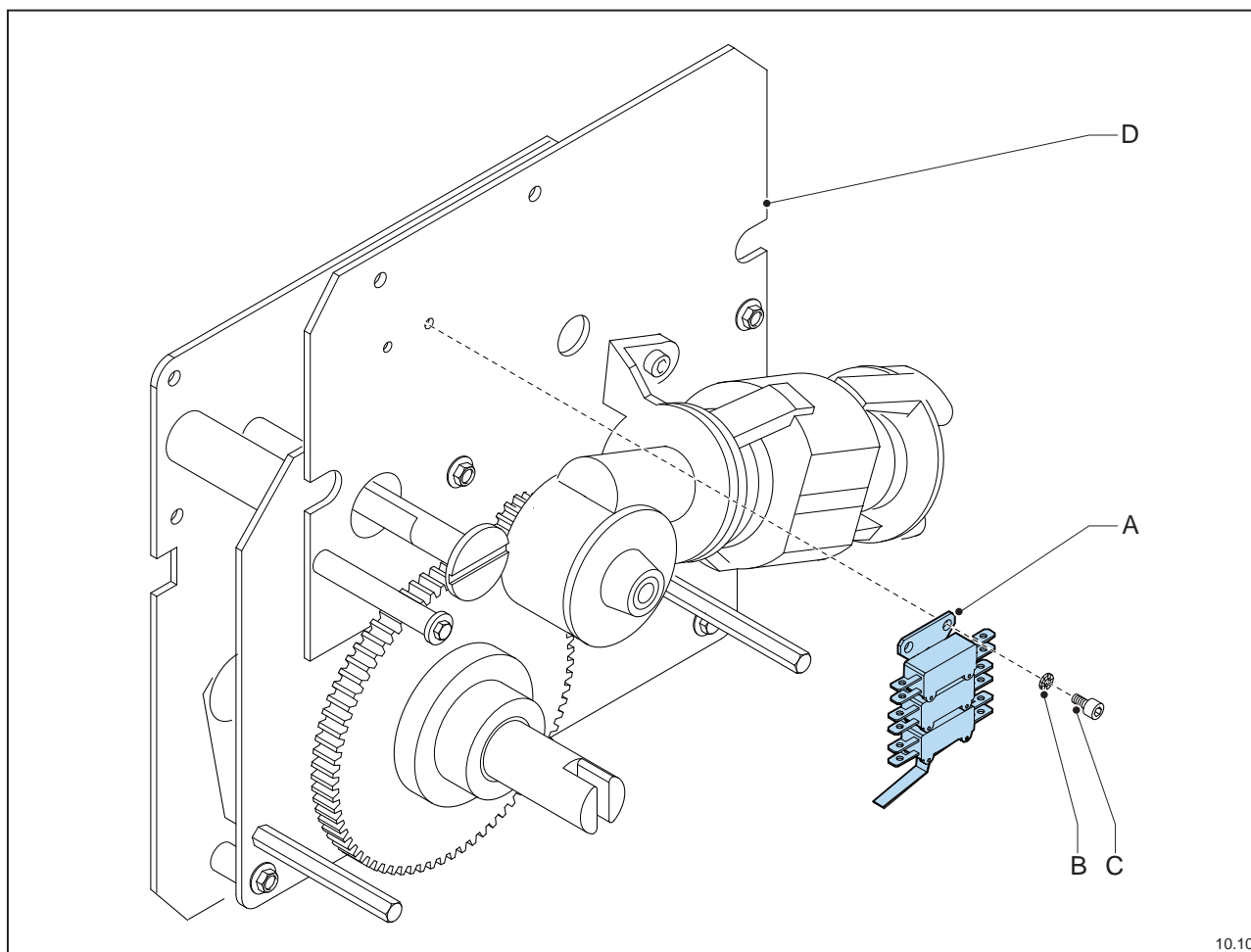

10.10

- Mount the carrier plate with the auxiliary contacts (fig. 10.10A) using the cylindrical screws (fig. 10.10C) and the lock washers (fig. 10.10B) on the front plate (fig. 10.10D). The front plate is provided with holes for this.

#### **9.1.4.4 DA-EDN-D – Auxiliary contact(s) on the load break switch**

For mounting auxiliary contacts on the load break switch of the DA-EDN-D-drive mechanism, several mounting kits are available.

The composition of these mounting kits vary, depending on factors such as:

- number of contacts ordered
- version (left or right-handed) of the auxiliary contacts
- type of auxiliary contact (shaft or wheel)

In all cases, the auxiliary contacts have already been pre-mounted on the carrier plate.

#### 9.1.4.4.1 Available auxiliary contacts

order number	description
OP401001	1x auxiliary contact – wheel, left-handed model, on carrier plate for one auxiliary contact
OP401011	1x auxiliary contact – wheel, left-handed model, on carrier plate for two auxiliary contacts
OP401100	1x auxiliary contact – shaft, right-handed model, on carrier plate for one auxiliary contact
OP401101	1x auxiliary contact – shaft, left-handed model, on carrier plate for one auxiliary contact
OP401110	1x auxiliary contact – shaft, right-handed model, on carrier plate for two auxiliary contacts
OP402010	2x auxiliary contact – wheel, right-handed model, on carrier plate for two auxiliary contacts
OP402011	2x auxiliary contact – wheel, left-handed model, on carrier plate for two auxiliary contacts
OP402110	2x auxiliary contact – shaft, right-handed model, on carrier plate for two auxiliary contacts
OP402111	2x auxiliary contact – shaft, left-handed model, on carrier plate for two auxiliary contacts
OP403021	3x auxiliary contact – wheel, left-handed model, on carrier plate for three auxiliary contacts
OP403121	3x auxiliary contact – shaft, left-handed model, on carrier plate for three auxiliary contacts

- See following table.

order number	description	number	pos. no.
OP401011	1x auxiliary contact – wheel, left-handed model, on carrier plate for two auxiliary contacts	1	fig. 10.13A
GR041604	DIN 6798A Ø M4 lock washer	2	fig. 10.13B
GR040909	DIN 912 M4x6 cylindrical screw	2	fig. 10.13C

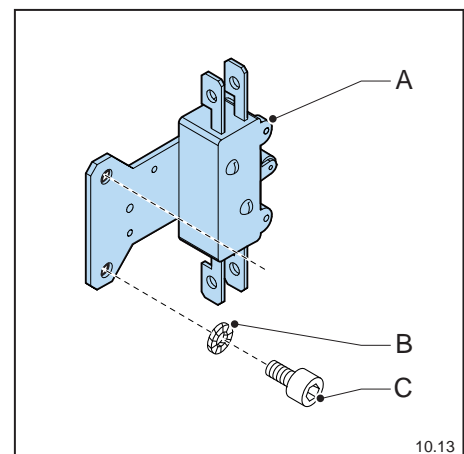

#### 9.1.4.4.2 Mounting instructions



For preparing and finishing work, see “Preparation for mounting” and “Final check and commissioning” respectively.

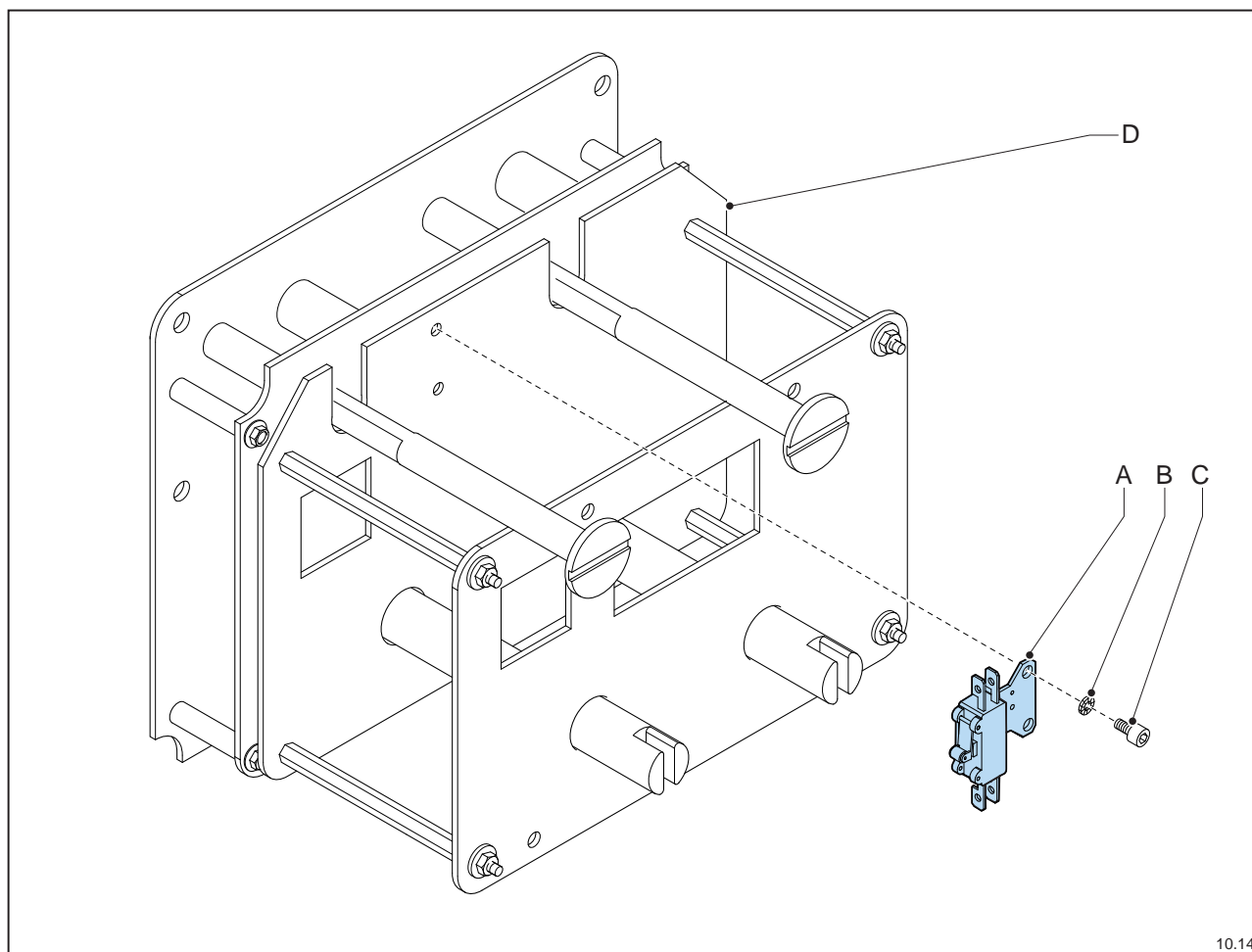

10.14

- Mount the carrier plate with the auxiliary contacts (fig. 10.14A) using the cylindrical screws (fig. 10.14C) and the lock washers (fig. 10.14B) on the back plate (fig. 10.14D). The back plate is provided with holes for this.

#### **9.1.4.5 DA-M – Auxiliary contacts for the key lock on the load break switch/earth switch**

For mounting auxiliary contacts for the key locks on the load break switch and/or earth switch of the DA-M-drive mechanism, several mounting kits are available.

The composition of these mounting kits vary, depending on factors such as:

- number of contacts ordered
- version (left or right-handed) of the auxiliary contacts
- type of auxiliary contact (shaft or wheel)

In all cases, the auxiliary contacts have already been pre-mounted on the carrier plate.



If load break switches of motor-operated drive mechanisms are provided with key locks, the associated auxiliary contacts must always be mounted.

The example below deals with mounting auxiliary contacts at the key locks of the load break switch. The method of mounting is identical to that of the earth switch.

#### 9.1.4.5.1 Available auxiliary contacts

order number	description
OP401001	1x auxiliary contact – wheel, left-handed model, on carrier plate for one auxiliary contact
OP401011	1x auxiliary contact – wheel, left-handed model, on carrier plate for two auxiliary contacts
OP401100	1x auxiliary contact – shaft, right-handed model, on carrier plate for one auxiliary contact
OP401101	1x auxiliary contact – shaft, left-handed model, on carrier plate for one auxiliary contact
OP401110	1x auxiliary contact – shaft, right-handed model, on carrier plate for two auxiliary contacts
OP402010	2x auxiliary contact – wheel, right-handed model, on carrier plate for two auxiliary contacts
OP402011	2x auxiliary contact – wheel, left-handed model, on carrier plate for two auxiliary contacts
OP402110	2x auxiliary contact – shaft, right-handed model, on carrier plate for two auxiliary contacts
OP402111	2x auxiliary contact – shaft, left-handed model, on carrier plate for two auxiliary contacts
OP403021	3x auxiliary contact – wheel, left-handed model, on carrier plate for three auxiliary contacts
OP403121	3x auxiliary contact – shaft, left-handed model, on carrier plate for three auxiliary contacts

- See following table.

order number	description	number	pos. no.
OP402011	2x auxiliary contact – wheel, left-handed model, on carrier plate for two auxiliary contacts	2	fig. 10.07A
GR041604	DIN 6798A Ø M4 lock washer	4	fig. 10.07B
GR040909	DIN 912 M4x6 cylindrical screw	4	fig. 10.07C

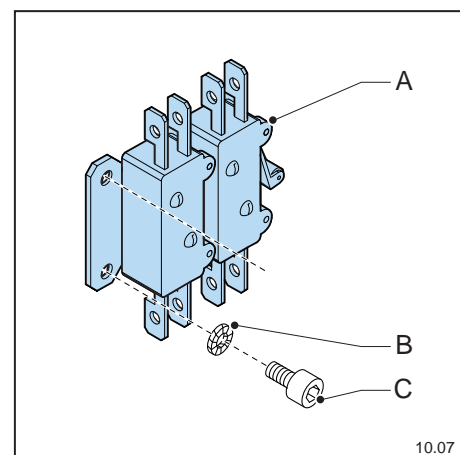

#### 9.1.4.5.2 Mounting instructions



For preparing and finishing work, see “Preparation for mounting” and “Final check and commissioning” respectively.

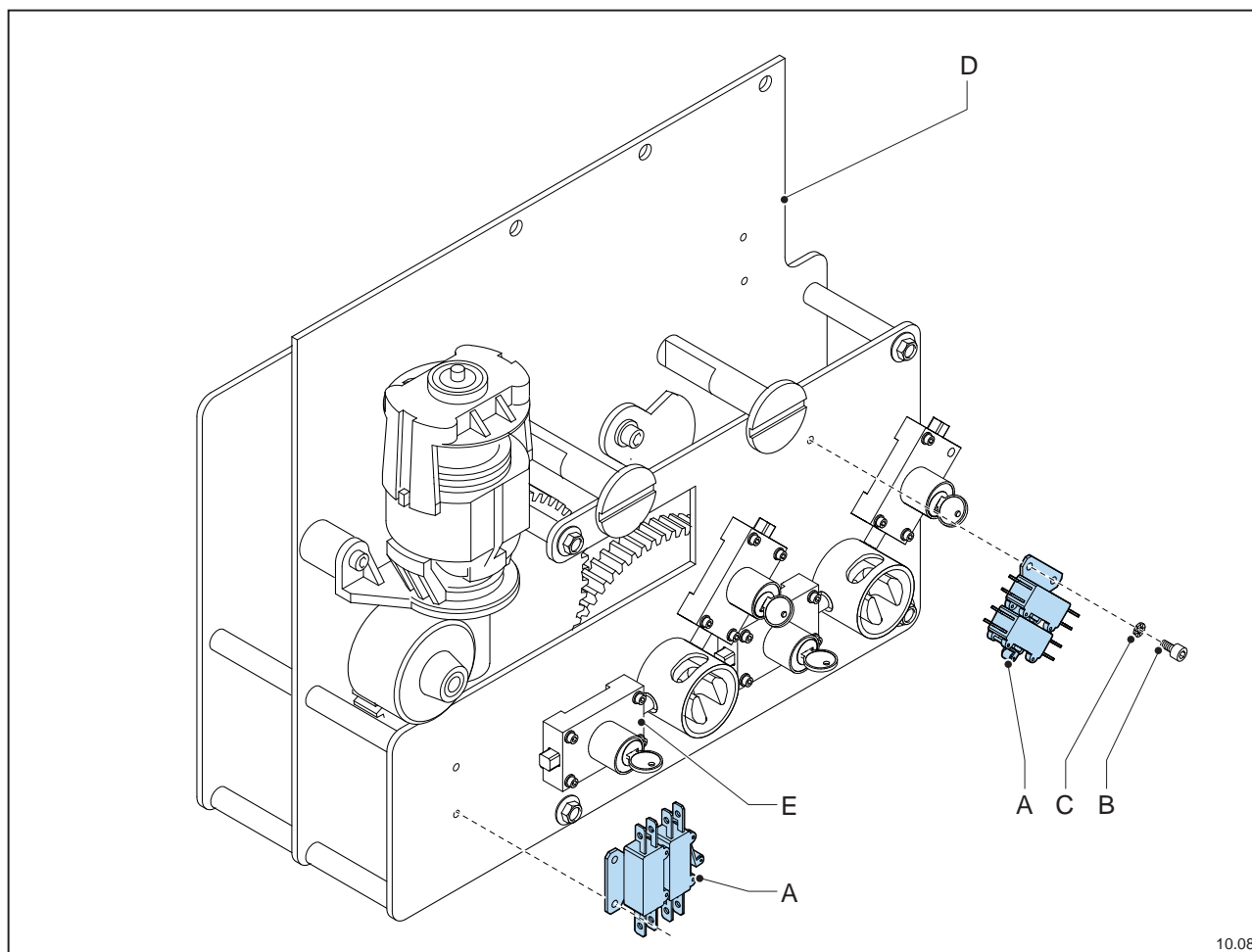

10.08

- Mount the carrier plate with the auxiliary contacts (fig. 10.08A) using the cylindrical screws (fig. 10.08B) and the lock washers (fig. 10.08C) on the front plate (fig. 10.08D). The front plate is provided with holes for this.



When there are key locks (fig. 10.08E) on the load break switch, an auxiliary contact must always be mounted.

#### 9.1.4.6 DA – Auxiliary contact(s) on the load break switch/earth switch

For mounting auxiliary contacts on the load break switch and/or earth switch of the DA-drive mechanism, several mounting kits are available.

The composition of these mounting kits vary, depending on factors such as:

- number of contacts ordered
- version (left or right-handed) of the auxiliary contacts
- type of auxiliary contact (shaft or wheel)

In all cases, the auxiliary contacts have already been pre-mounted on the carrier plate.

### 9.1.4.6.1 Available auxiliary contacts

order number	description
OP401001	1x auxiliary contact – wheel, left-handed model, on carrier plate for one auxiliary contact
OP401011	1x auxiliary contact – wheel, left-handed model, on carrier plate for two auxiliary contacts
OP401100	1x auxiliary contact – shaft, right-handed model, on carrier plate for one auxiliary contact
OP401101	1x auxiliary contact – shaft, left-handed model, on carrier plate for one auxiliary contact
OP401110	1x auxiliary contact – shaft, right-handed model, on carrier plate for two auxiliary contacts
OP402010	2x auxiliary contact – wheel, right-handed model, on carrier plate for two auxiliary contacts
OP402011	2x auxiliary contact – wheel, left-handed model, on carrier plate for two auxiliary contacts
OP402110	2x auxiliary contact – shaft, right-handed model, on carrier plate for two auxiliary contacts
OP402111	2x auxiliary contact – shaft, left-handed model, on carrier plate for two auxiliary contacts
OP403021	3x auxiliary contact – wheel, left-handed model, on carrier plate for three auxiliary contacts
OP403121	3x auxiliary contact – shaft, left-handed model, on carrier plate for three auxiliary contacts

- See following table.

order number	description	number	pos. no.
DA980097	mounting plate with auxiliary contact(s), pre-mounted on carrier plate(s). (for available auxiliary contacts, see overview above).	1	fig. 10.03A
GR041308	DIN 6923 M8 hexagon nut with collar (Ripp class 10)	4	fig. 10.03B
GR041508	DIN 125 Ø M8 flat washer	2	fig. 10.03C
GR041608	DIN 6798A Ø M8 lock washer	2	fig. 10.03D
GR040825	DIN 933 M8x25 hexagonal tap bolt	2	fig. 10.03E

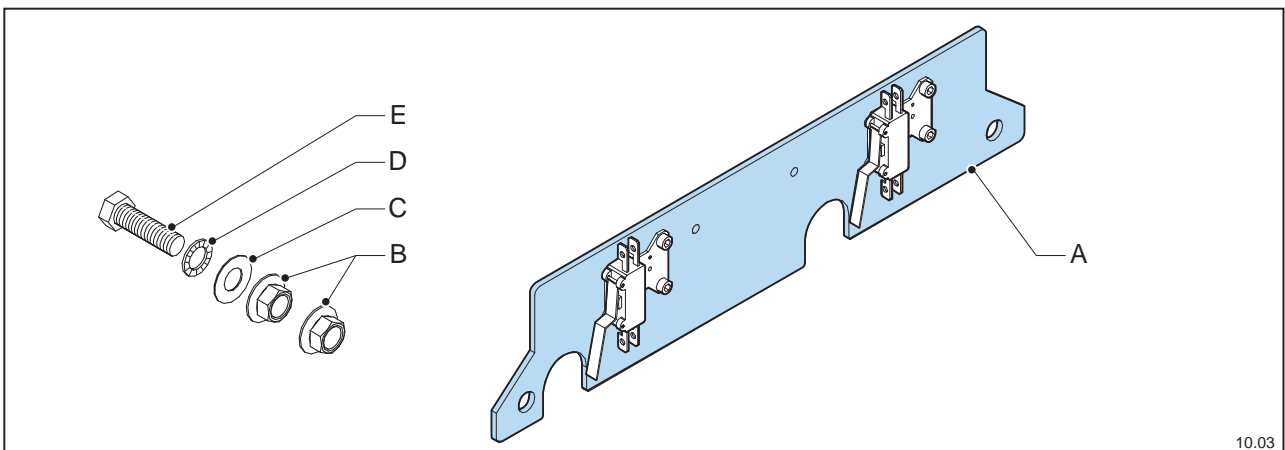

10.03



### 9.1.4.6.2 Mounting instructions



For preparing and finishing work, see “Preparation for mounting” and “Final check and commissioning” respectively.

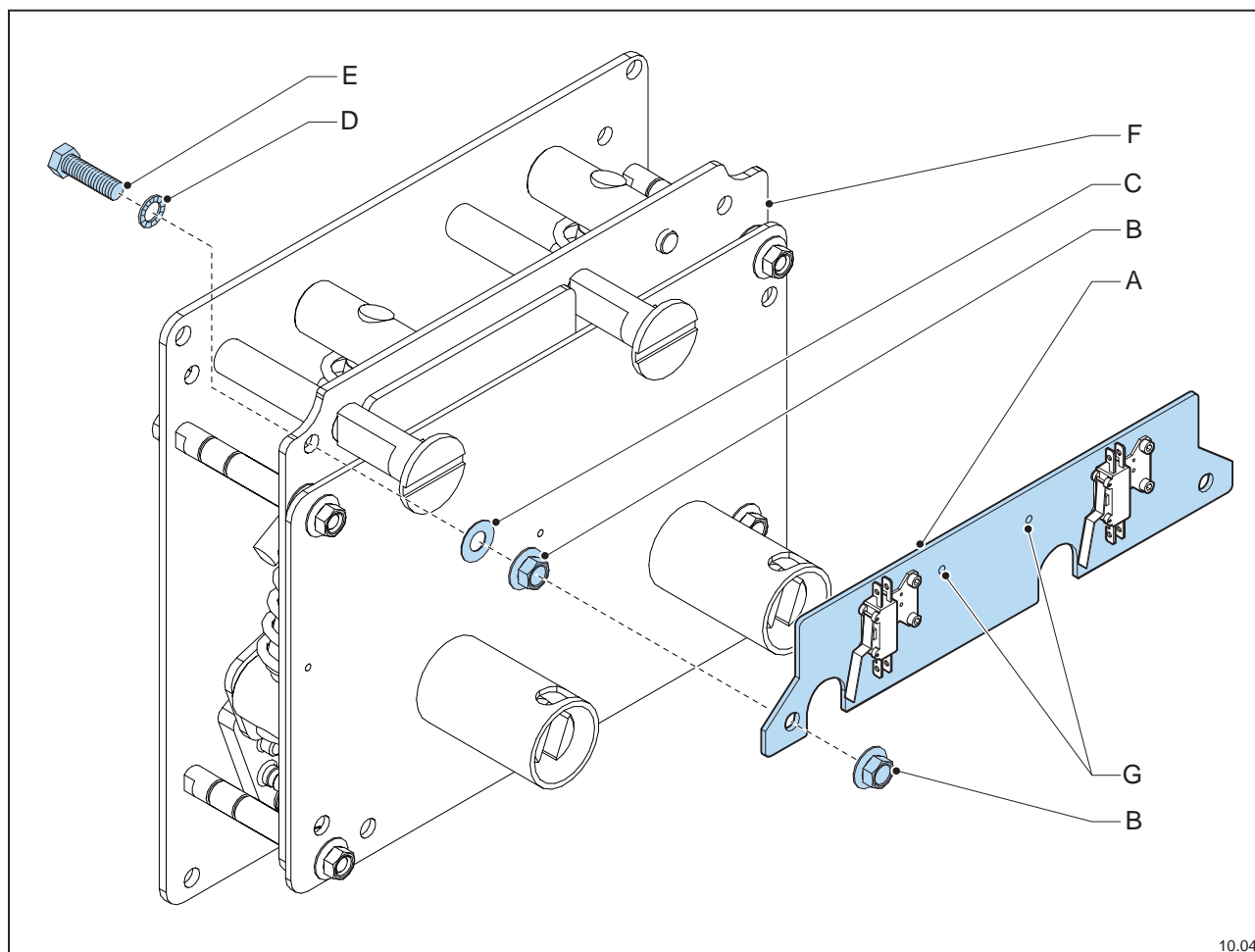

10.04

- Fit the hexagonal tap bolt (fig. 10.04E), with the lock washer (fig. 10.04D) in the holes of the front plate (fig. 10.04F).
- Remove the flat washers (fig. 10.04C) on the wire ends.
- Mount a hexagon nut on each wire end (fig. 10.04B) and retighten the hexagon nuts.
- Mount the mounting plate (fig. 10.04A) with the mounted auxiliary contacts over the wire ends.
- Secure the whole assembly by screwing a second hexagon nut onto each wire end (fig. 10.04B).



Thanks to the two holes (G) in the mounting plate, a DIN rail can be mounted easily on which a terminal strip can be fitted.

### 9.1.4.7 DA-M – Auxiliary contacts on the earth switch

For mounting auxiliary contacts on the earth switch of the DA-M-drive mechanism, several mounting kits are available.

The composition of these mounting kits vary, depending on factors such as:

- number of contacts ordered
- version (left or right-handed) of the auxiliary contacts
- type of auxiliary contact (shaft or wheel)

In all cases, the auxiliary contacts have already been pre-mounted on the carrier plate.

#### 9.1.4.7.1 Available auxiliary contacts

order number	description
OP401001	1x auxiliary contact – wheel, left-handed model, on carrier plate for one auxiliary contact
OP401011	1x auxiliary contact – wheel, left-handed model, on carrier plate for two auxiliary contacts
OP401100	1x auxiliary contact – shaft, right-handed model, on carrier plate for one auxiliary contact
OP401101	1x auxiliary contact – shaft, left-handed model, on carrier plate for one auxiliary contact
OP401110	1x auxiliary contact – shaft, right-handed model, on carrier plate for two auxiliary contacts
OP402010	2x auxiliary contact – wheel, right-handed model, on carrier plate for two auxiliary contacts
OP402011	2x auxiliary contact – wheel, left-handed model, on carrier plate for two auxiliary contacts
OP402110	2x auxiliary contact – shaft, right-handed model, on carrier plate for two auxiliary contacts
OP402111	2x auxiliary contact – shaft, left-handed model, on carrier plate for two auxiliary contacts
OP403021	3x auxiliary contact – wheel, left-handed model, on carrier plate for three auxiliary contacts
OP403121	3x auxiliary contact – shaft, left-handed model, on carrier plate for three auxiliary contacts

- See following table.

order number	description	number	pos. no.
OP402110	2x auxiliary contact – shaft, right-handed model, on carrier plate for two auxiliary contacts	1	fig. 10.05A
GR041604	DIN 6798A Ø M4 lock washer	2	fig. 10.05B
GR040909	DIN 912 M4x6 cylindrical screw	2	fig. 10.05C

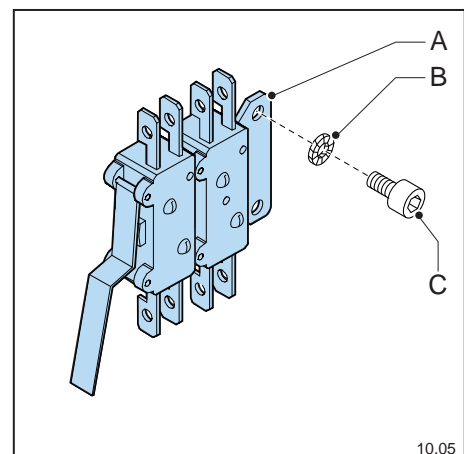

### 9.1.4.7.2 Mounting instructions



For preparing and finishing work, see “Preparation for mounting” and “Final check and commissioning” respectively.

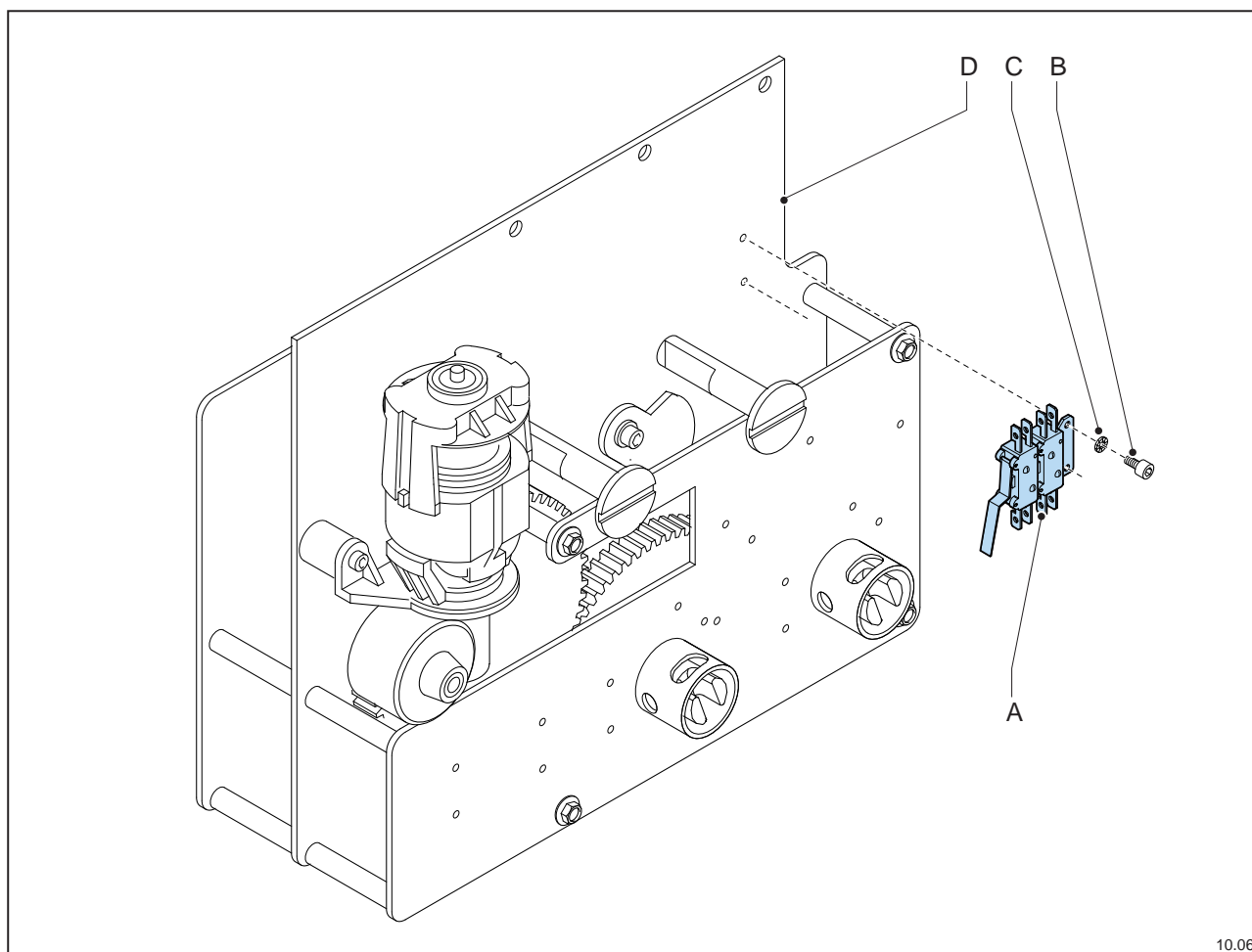

10.06

- Dismount the existing auxiliary contact:
  - Disconnect the plug connections.
  - Loosen the cylindrical screws (fig. 10.06B).
  - Remove the lock washers (fig. 10.06C).
  - Remove the carrier plate (fig. 10.06A) with the existing auxiliary contact.
- Mount the new carrier plate with the auxiliary contacts using the cylindrical screws and the lock washers on the front plate (fig. 10.06D).

### 9.1.4.8 DP – Auxiliary contact for indicating the status of fuses

For mounting the auxiliary contact that indicates the status of the fuses (tripped - not tripped) a special mounting kit is available for the DP-drive mechanism. The auxiliary contact has already been pre-mounted on the carrier plate.

- See following table.

order number	description	number	pos. no.
OP501111	1x auxiliary contact, adjusted for indicating the status of fuses	1	fig. 10.17A
GR041604	DIN 6798A Ø M4 lock washer	2	fig. 10.17B
GR040909	DIN 912 M4x6 cylindrical screw	2	fig. 10.17C
GR040738	DIN84 M5x40 cylindrical screw with slot	1	fig. 10.17D
GR041005	DIN 934 hexagon nut M5	6	fig. 10.17E
GR041105	DIN 985 lock nut M5	1	fig. 10.17F
GR040739	DIN84 M5x60 cylindrical screw with slot	1	fig. 10.17G
DP995210	Indicator position fuses WG + ZG	1	fig. 10.17H
GR102520	Nylon bearing bush type ø8 ø5 x ø10 x ø20	1	fig. 10.17I

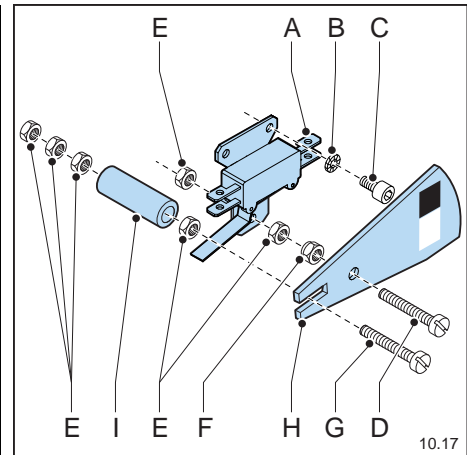

#### 9.1.4.8.1 Mounting instructions



For preparing and finishing work, see “Preparation for mounting” and “Final check and commissioning” respectively.

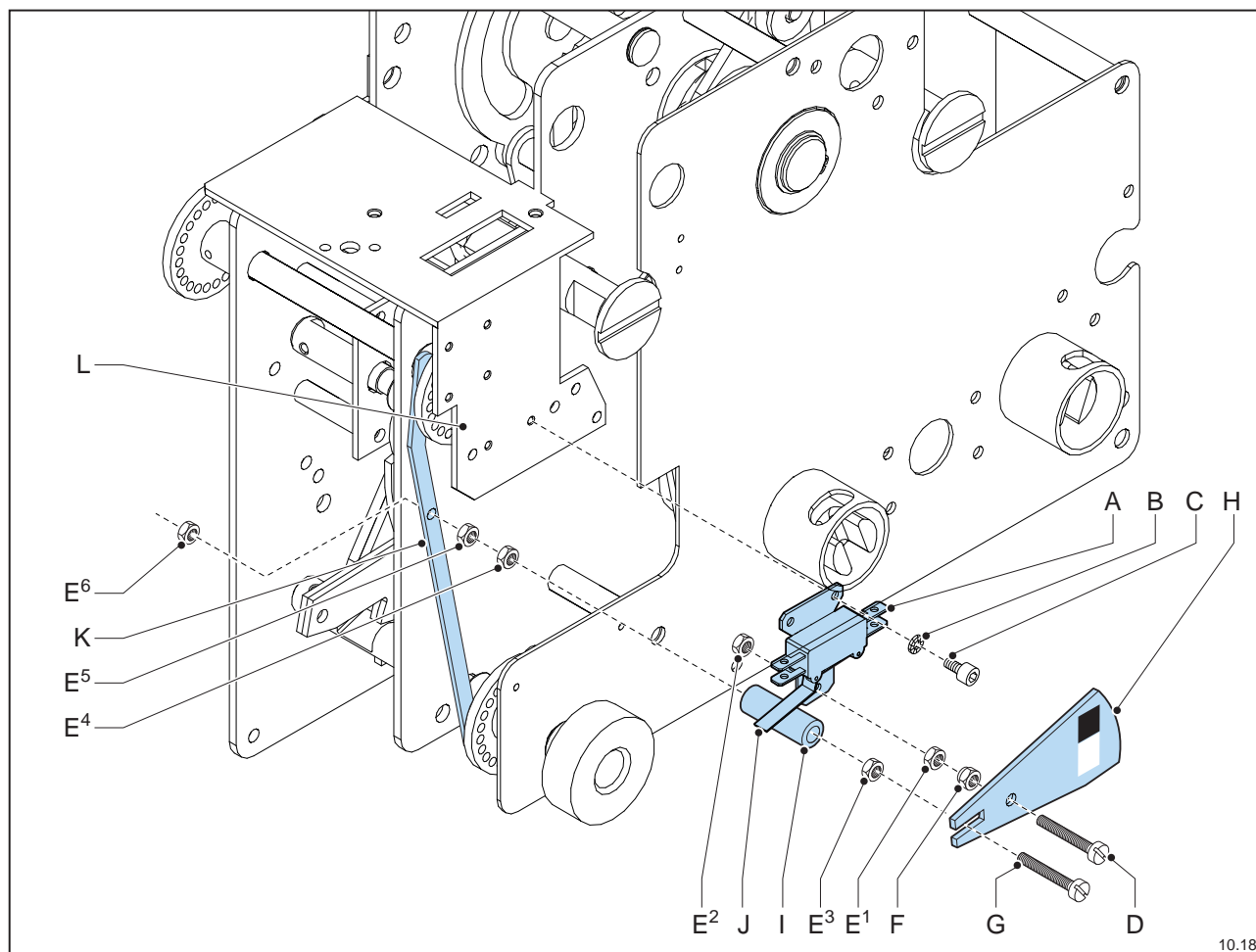

- Place the cylindrical screw (fig. 10.18D) into the indicator (fig. 10.18H).
- Screw the lock nut (fig. 10.18F) onto the screw.  
Tighten the lock nut as much as possible until the indicator can still turn freely on the screw.
- Screw the nut (fig. 10.18E<sup>1</sup>) about 1 cm onto the screw.
- Place the screw with the indicator into the carrier plate of the auxiliary contact (fig. 10.18A).
- Fix the screw on the carrier plate using the hexagon nut (fig. 10.18E<sup>2</sup>).
- Screw the hexagon nut (fig. 10.18E<sup>3</sup>) onto the screw (fig. 10.18G).  
Tighten the nut until about 3 mm from the screw head.
- Place the nylon bearing bush (fig. 10.18I) onto the screw.
- Screw the hexagon nut (fig. 10.18E<sup>4</sup>) onto the screw.  
Fully tighten the nut.
- Screw the hexagon nut (fig. 10.18E<sup>5</sup>) about 1 cm onto the screw.
- Screw the screw (fig. 10.18G) into the shaft (fig. 10.18K) of the tripping mechanism in such a way, that the hexagon nut lies against the shaft.
- Fix the screw on the shaft using the second hexagon nut (fig. 10.18E<sup>6</sup>).
- Mount the carrier plate with the auxiliary contact and the indicator using the cylindrical screws (fig. 10.18C) and the lock washers (fig. 10.18B) on the support plate (fig. 10.18L) for the shunt-trip release.  
The support plate is provided with holes for this.



The shaft (fig. 10.18J) of the auxiliary contact must point down and rest upon the nylon bearing bush.

The slot in the indicator must be between the nut and the head of the screw (fig. 10.18G). Adjust the screw, if necessary:

- Loosen both hexagonal nuts (fig. 10.18E<sup>5</sup> and E<sup>6</sup>) and turn the screw in or out.
- Tighten the hexagonal nuts.

- Check the operation of the auxiliary contact by moving the tripping mechanism up and down by hand.

#### 9.1.4.9 DP-M – Auxiliary contact for indicating the status of fuses

For mounting the auxiliary contact that indicates the status of the fuses (tripped - not tripped) a special mounting kit is available for the DP-M-drive mechanism.

The auxiliary contact has already been pre-mounted on the carrier plate.

- See following table.

order number	description	number	pos. no.
OP501101	1x auxiliary contact, adjusted for indicating the status of fuses	1	fig. 10.17A
GR041604	DIN 6798A Ø M4 lock washer	2	fig. 10.17B
GR040909	DIN 912 M4x6 cylindrical screw	2	fig. 10.17C
GR040738	DIN84 M5x 40 cylindrical screw with slot	1	fig. 10.17D
GR041005	DIN 934 hexagon nut M5	6	fig. 10.17E
GR041105	DIN 985 lock nut M5	1	fig. 10.17F
GR040739	DIN84 M5x60 cylindrical screw with slot	1	fig. 10.17G
DP995210	Indicator position fuses WG + ZG	1	fig. 10.17H
GR102520	Nylon bearing bush type ø8 ø5 x ø10 x ø20	1	fig. 10.17I

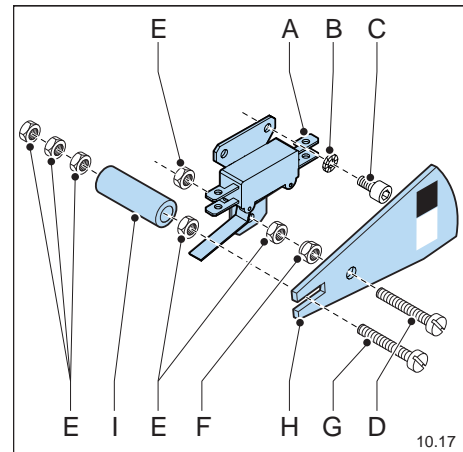

### 9.1.4.9.1 Mounting instructions



For preparing and finishing work, see “Preparation for mounting” and “Final check and commissioning” respectively.

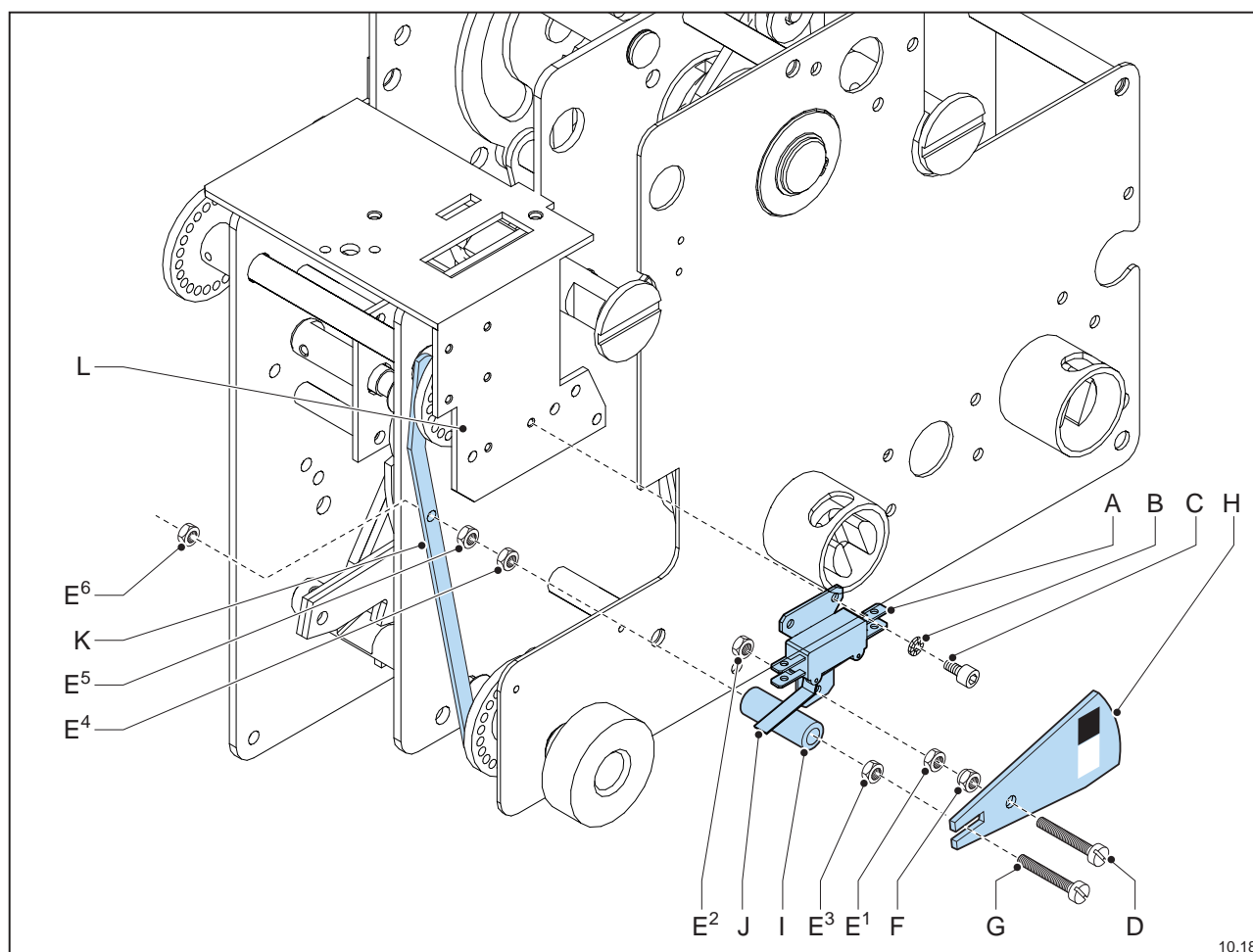

- Place the cylindrical screw (fig. 10.18D) into the indicator (fig. 10.18H).
- Screw the lock nut (fig. 10.18F) onto the screw.  
Tighten the lock nut as much as possible until the indicator can still turn freely on the screw.
- Screw the nut (fig. 10.18E<sup>1</sup>) about 1 cm onto the screw.
- Place the screw with the indicator into the carrier plate of the auxiliary contact (fig. 10.18A).
- Fix the screw on the carrier plate using the hexagon nut (fig. 10.18E<sup>2</sup>).
- Screw the hexagon nut (fig. 10.18E<sup>3</sup>) onto the screw (fig. 10.18G).  
Tighten the nut until about 3 mm from the screw head.
- Place the nylon bearing bush (fig. 10.18I) onto the screw.
- Screw the hexagon nut (fig. 10.18E<sup>4</sup>) onto the screw.  
Fully tighten the nut.
- Screw the hexagon nut (fig. 10.18E<sup>5</sup>) about 1 cm onto the screw.
- Screw the screw (fig. 10.18G) into the shaft (fig. 10.18K) of the tripping mechanism in such a way, that the hexagon nut lies against the shaft.

- Fix the screw on the shaft using the second hexagon nut (fig. 10.18E<sup>6</sup>).
- Mount the carrier plate with the auxiliary contact and the indicator using the cylindrical screws (fig. 10.18C) and the lock washers (fig. 10.18B) on the support plate (fig. 10.18L) for the shunt-trip release.

The support plate is provided with holes for this.



The shaft (fig. 10.18J) of the auxiliary contact must point down and rest upon the nylon bearing bush.

The slot in the indicator must be between the nut and the head of the screw (fig. 10.18G). Adjust the screw, if necessary:

- Loosen both hexagonal nuts (fig. 10.18E<sup>5</sup> and E<sup>6</sup>) and turn the screw in or out.
  - Tighten the hexagonal nuts.
- Check the operation of the auxiliary contact by moving the tripping mechanism up and down by hand.

## 9.2 Key locks

Key locks (in the form of Ronis locks) can be attached to the drive mechanism on different places to lock the shaft of the load break switch and/or the shaft of the earth switch. In this way the cell is also adequately protected against unintended opening and closing of the switch(es) involved.



The locking of the switches of the motor-operated drive-mechanisms must always involve **two** locks per switch; the left-hand lock locks the switch in OPEN position, the right-hand lock locks the switch in CLOSED position.

Besides, when the key locks are mounted on the load break switch of motor-operated drive mechanisms, mounting the corresponding auxiliary contacts is obliged. See “DA-M – Auxiliary contacts for the key locks on the load break switch/earth switch”.

### 9.2.1 Preparation for mounting

The following preparations must always be taken **before** you start mounting one or more key locks:

- Make the entire medium voltage board voltage free.

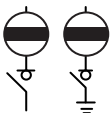

Open the particular cell as well as the load isolation and the earth switches (if present).



- Dismount the front panel:
  - Loosen the four hexagonal tap bolts (fig. 10.01C)
  - Remove the four washers (fig. 10.01B).
  - Remove the front panel (fig. 10.01A).

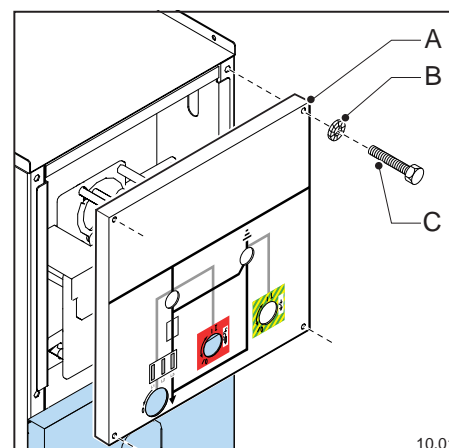

10.01

## 9.2.2 Mounting of key locks - general

Special mounting kits are available for mounting key locks.

The composition of these mounting kits and thus the method and/or order of mounting, varies depending on factors such as:

- type of drive mechanism
- function (position) of the key lock
- number of key locks to be mounted

**i** The table with the accompanying figure shows the composition of a **standard key lock set**. Dependent on the function (and therefore the position) of the key locks, the drive-mechanism type (and so the number of key locks to be mounted) this composition may be changed.

For further information and detailed mounting instructions **for each specific mounting kit**, see “Mounting of key locks – specific (for each drive mechanism)”

order number	description	number	pos. no.
OP100000	Ronis lock, incl. key	1	fig. 10.50A
GR040922	DIN 912 M5x25 cylindrical screw	4	fig. 10.50B
GR041705	Ø M5 contact locking ring	4	fig. 10.50C

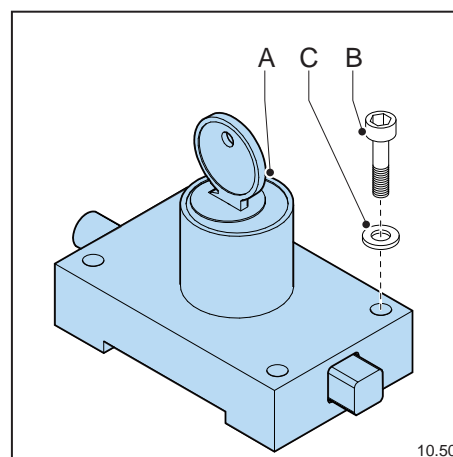

10.50

### 9.2.3 Final checking and commissioning

The following actions must always be carried out **after** mounting one or more key locks:

- Check that the fitting materials are properly attached.
- Check the operation of the key locks.
- If the key locks are mounted on the load break switch of motor-operated drive mechanisms, always mount the associated auxiliary contacts. See “DA-M – Auxiliary contacts for the key locks on the load break switch/earth switch”.
- Mount the front panel.
- Put the particular cell into operation: earth switch (if present) OPEN, load break switch CLOSED.
- Put the medium voltage board back into operation.

### 9.2.4 Mounting of key locks – specific (for each drive mechanism)

#### 9.2.4.1 DP – Key locks on the earth switch

For mounting the two key locks on the load break switch of the DP-drive mechanism, a specific mounting kit is available.

- See following table.

order number	description	number	pos. no.
OP100000	Ronis lock, incl. key	2	fig. 10.54A
GR040922	DIN 912 M5x25 cylindrical screw	7	fig. 10.54B
GR041705	Ø M5 contact locking ring	7	fig. 10.54C
GR041105	DIN 985 lock nut nylon ring M5	7	fig. 10.54D

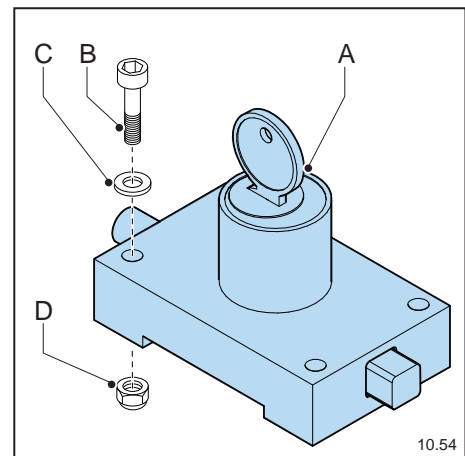

#### 9.2.4.1.1 Mounting instructions



For preparing and finishing work, see “Preparation for mounting” and “Final check and commissioning” respectively.

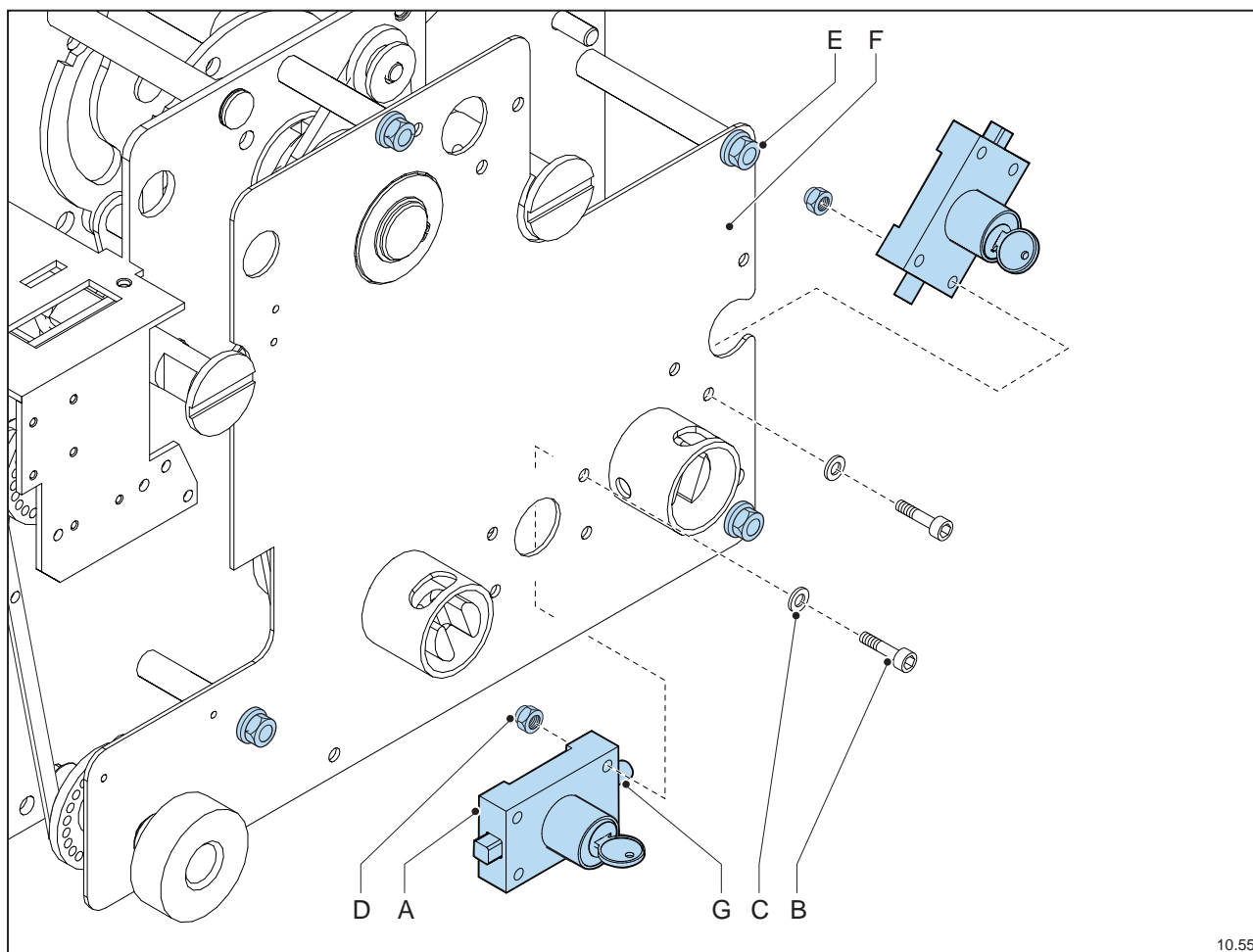

10.55

- Loosen the four hexagonal bolts (fig. 10.55E) of the front plate a few strokes.
- Pull the front plate (fig. 10.55F) forward until there is enough space between the front plate and the back plate.
- Mount the key locks (fig. 10.55A) using the cylindrical screws (fig. 10.55B), the contact locking rings (fig. 10.55C) and the self-locking hexagonal nuts (fig. 10.55D) on the back side of the front plate.



The rounded side of the lock (fig. 10.55G) must smoothly fall into the slot of the shaft of the switch.

- Fix the front plate using the four hexagonal bolts.

### 9.2.4.2 DP – Key lock on the load break switch

For mounting the key lock on the load break switch of the DP-drive mechanism, a specific mounting kit is available.

- See following table.

order number	description	number	pos. no.
OP100000	Ronis lock, incl. key	1	fig. 10.56A
GR040922	DIN 912 M5x25 cylindrical screw	3	fig. 10.56B
GR041705	Ø M5 contact locking ring	3	fig. 10.56C
GR041105	DIN 985 lock nut nylon ring M5	3	fig. 10.56D
DP994229	extension piece, completely pre-mounted	1	fig. 10.56E
GR040927	DIN 912 M6x10 cylindrical screw	1	fig. 10.56F
GR041706	M6 contact locking ring	1	fig. 10.56G

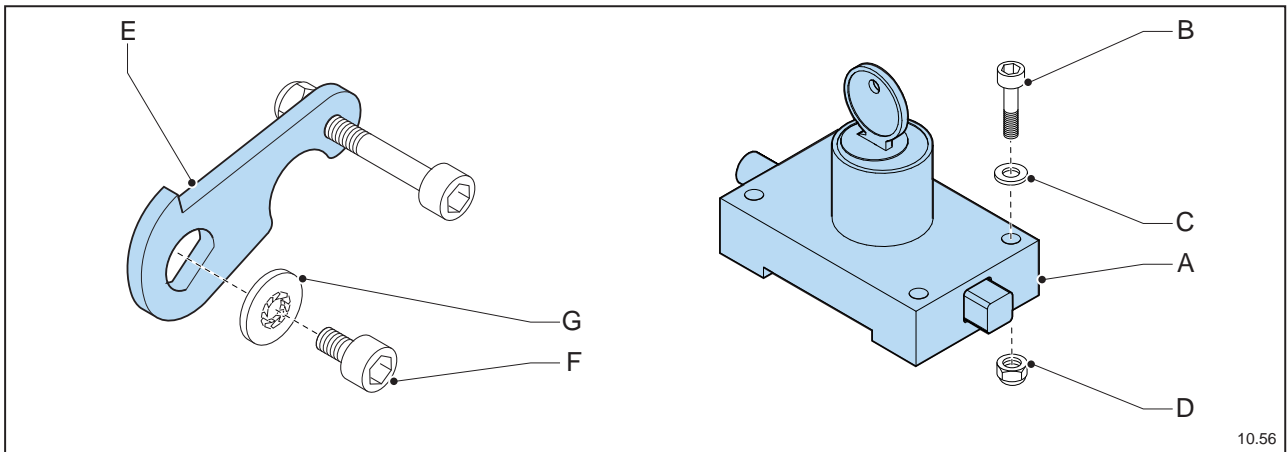

10.56

### 9.2.4.2.1 Mounting instructions



For preparing and finishing work, see “Preparation for mounting” and “Final check and commissioning” respectively.

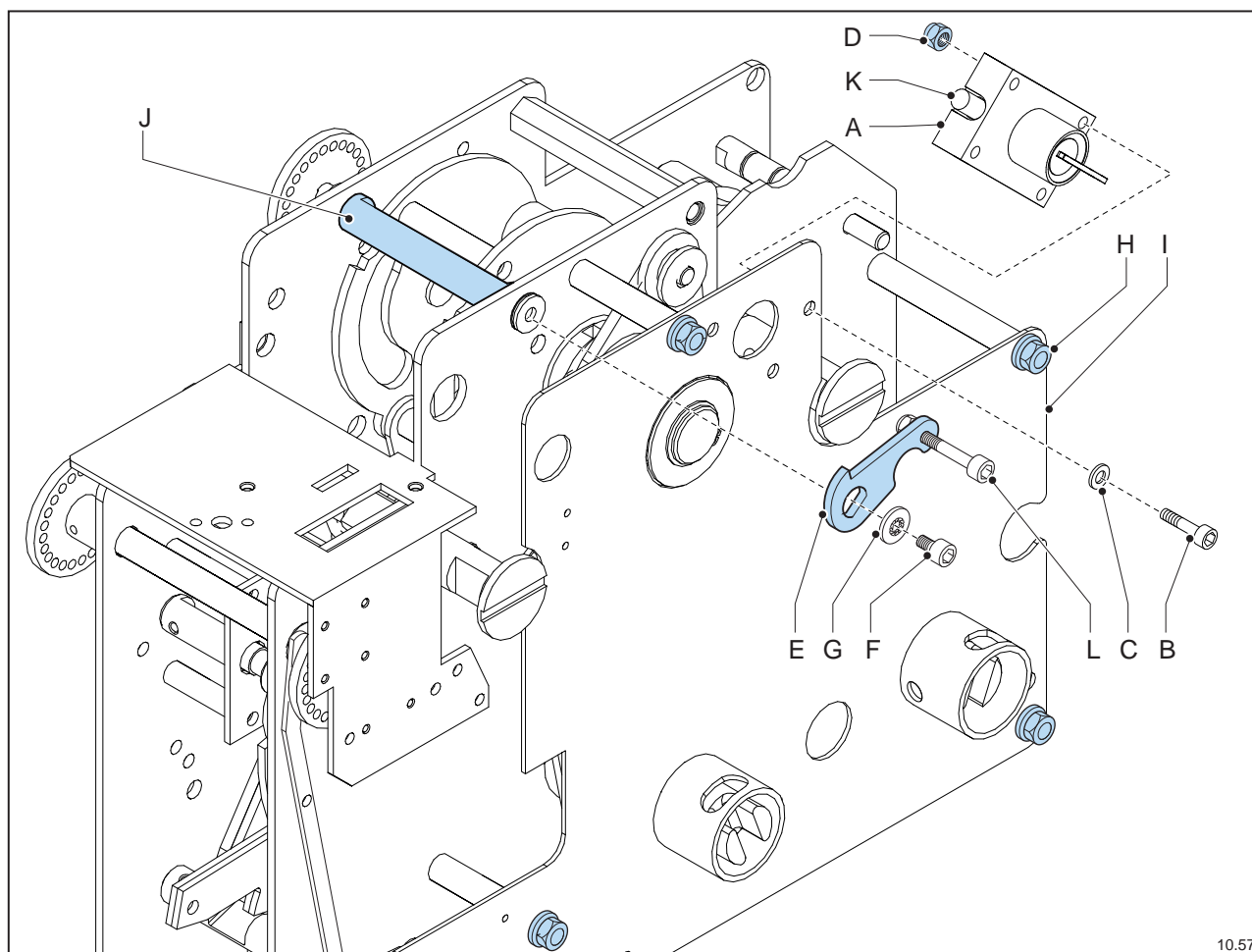

10.57

- Loosen the four hexagonal bolts (fig. 10.57H) of the front plate a few strokes.
- Pull the front plate (fig. 10.57I) forward until there is enough space between the front plate and the back plate.
- Mount the key lock (fig. 10.57A) using the cylindrical screws (fig. 10.57B), the contact locking rings (fig. 10.57C) and the self-locking hexagonal nuts (fig. 10.57D) on the back side of the front plate.
- Attach the pre-mounted extension piece (fig. 10.57E) using the cylindrical screw (fig. 10.57F) and the contact locking ring (fig. 10.57G) on the end of the locking shaft (fig. 10.57J).



The rounded side of the lock (fig. 10.57K) must be able to move the extension piece – through the cylindrical screw (fig 10.57L) - up and down to lock and unlock the load break switch.

- Fix the front plate using the four hexagonal bolts.

### 9.2.4.3 DA-M – Key locks on the load break switch/earth switch

For mounting the two key locks on the load break switch and/or earth switch of the DA-M-drive mechanism the standard set for each switch will be sufficient.

The example below deals with mounting the key locks on the load break switch. The method of mounting is identical to that of the key locks on the earth switch.

- See following table.

order number	description	number	pos. no.
OP100000	Ronis lock, incl. key	2	fig. 10.50A
GR040922	DIN 912 M5x25 cylindrical screw	8	fig. 10.50B
GR041705	Ø M5 contact locking ring	8	fig. 10.50C

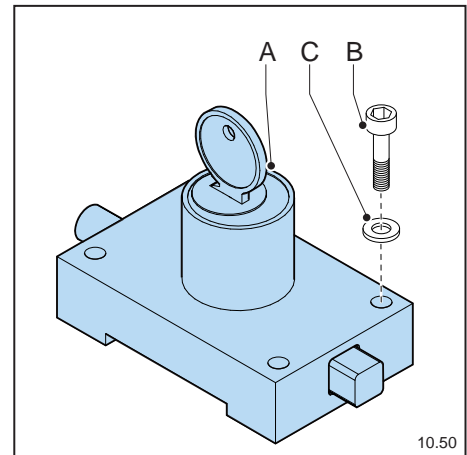

#### 9.2.4.3.1 Mounting instructions



For preparing and finishing work, see “Preparation for mounting” and “Final check and commissioning” respectively.

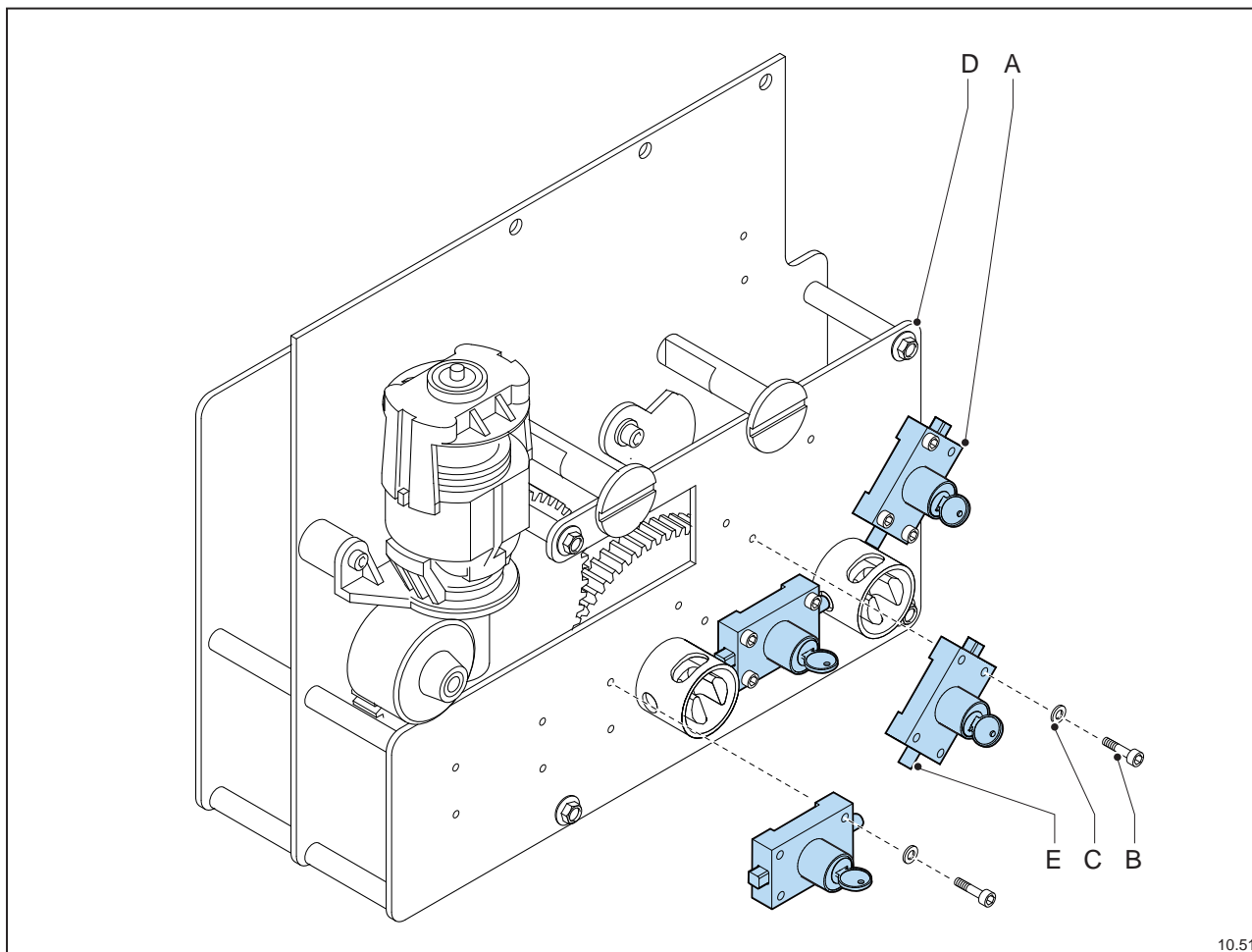

10.51

- Mount the key locks (fig. 10.51A) using the cylindrical screws (fig. 10.51B) and the contact locking rings (fig. 10.51C) on the front plate (fig. 10.51D).



The rounded side of the lock (fig. 10.51E) must smoothly fall into the slot of the shaft of the switch.

## 9.3 Shunt-trip releases

Shunt-trip releases can be mounted on the drive mechanism of cells with a fuse combination. With the help of these shunt-trip releases the load break switch can be opened automatically and from a distance.

### 9.3.1 Preparation for mounting

The following preparations must always be taken **before** you start mounting a shunt-trip release:

- Make the entire medium voltage board voltage free.

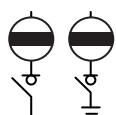

Open the particular cell as well as the load isolation and the earth switches.

- Dismount the front panel:
  - Loosen the four hexagonal tap bolts (fig. 10.01C)
  - Remove the four washers (fig. 10.01B).
  - Remove the front panel (fig. 10.01A).

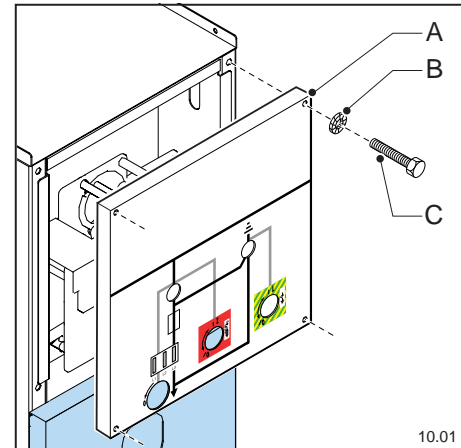

### 9.3.2 Mounting of shunt-trip releases - general

Special mounting kits are available for mounting shunt-trip releases.

The composition of these mounting kits and thus the method and/or order of mounting varies depending on the type of shunt-trip release.

For further information and detailed mounting instructions **for each specific mounting kit**, see “Mounting of shunt-trip releases – specific (for each drive mechanism)”

### 9.3.3 Final checking and commissioning

The following actions must always be carried out **after** mounting the shunt-trip release:

- Check that the fitting materials are properly attached.
- Electrically connect the shunt-trip release.
- Measure the shunt-trip release using a multimeter. If the shunt-trip release is supplied by an external power source, an auxiliary contact must always be placed.
- Mount the front panel.
- Put the particular cell into operation: earth switch (if present) OPEN, load break switch CLOSED.
- Put the medium voltage board back into operation.

### 9.3.4 Mounting of shunt-trip releases – specific (for each drive mechanism)

#### 9.3.4.1 DP, DP-M, DP-A, DP-A-M – Shunt-trip release on the load break switch

Special mounting kits are available for mounting the shunt-trip release. The composition of these mounting kits may vary to some extent, depending on the release type.

##### 9.3.4.1.1 Available release types

order number	description
OP210024	shunt-trip release 24 VDC/DP
OP210048	shunt-trip release 48 VDC/DP
OP210110	shunt-trip release 110 VDC/DP
OP211110	shunt-trip release 110 VAC/DP
OP211230	shunt-trip release 230 VAC/DP



- See following table.

order number	description	number	pos. no.
OP200110	shunt-trip release 5%, 110 VDC	1	fig. 10.70A
GR040909	DIN 912 M4x6 cylindrical screw	2	fig. 10.70B
GR041604	DIN 6798A Ø M4 lock washer	2	fig. 10.70C
GR041101	DIN 985 locking nut nylon ring M2,5	1	fig. 10.70D
GR041004	DIN 934 hexagonal nut M4	2	fig. 10.70E
GR040420	DIN 933 hexagonal tap bolt M4x20	1	fig. 10.70F
GR043130	DIN 94 split pin 3,2x20	1	fig. 10.70G
DP994195	shaft shunt-trip release	1	fig. 10.70H
GR003001	Loctite 270	1	fig. 10.70I

The mounting material is supplied in a plastic bag.

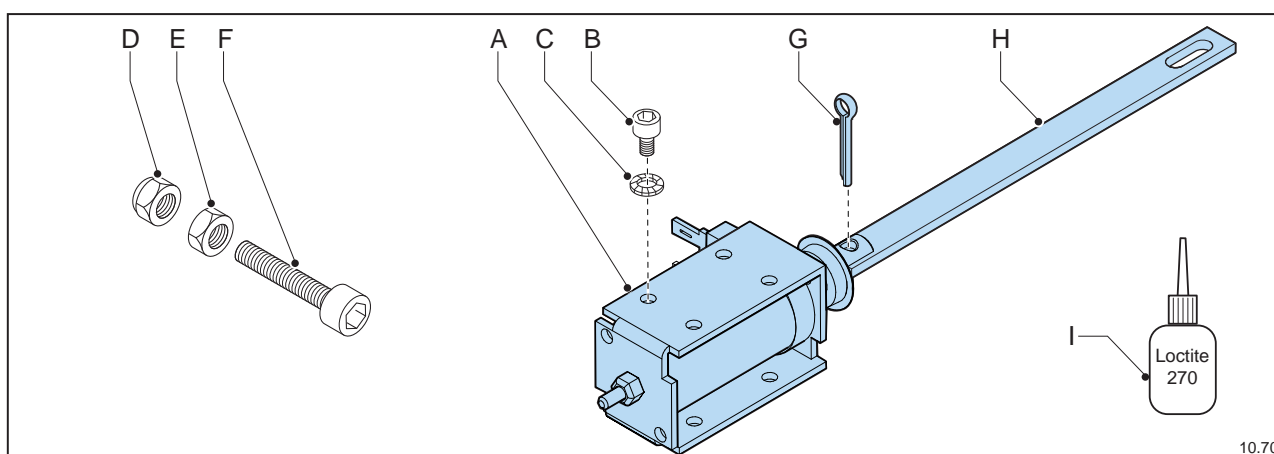

#### 9.3.4.1.2 Mounting instructions



For preparing and finishing work, see “Preparation for mounting” and “Final check and commissioning” respectively.



Never turn the cylindrical screws (fig. 10.71B) directly in the shunt trip release, to prevent the coils of the shunt trip release (fig. 10.71A) from damaging. The support plate (fig. 10.71I) must always be clamped between the release and the screws.

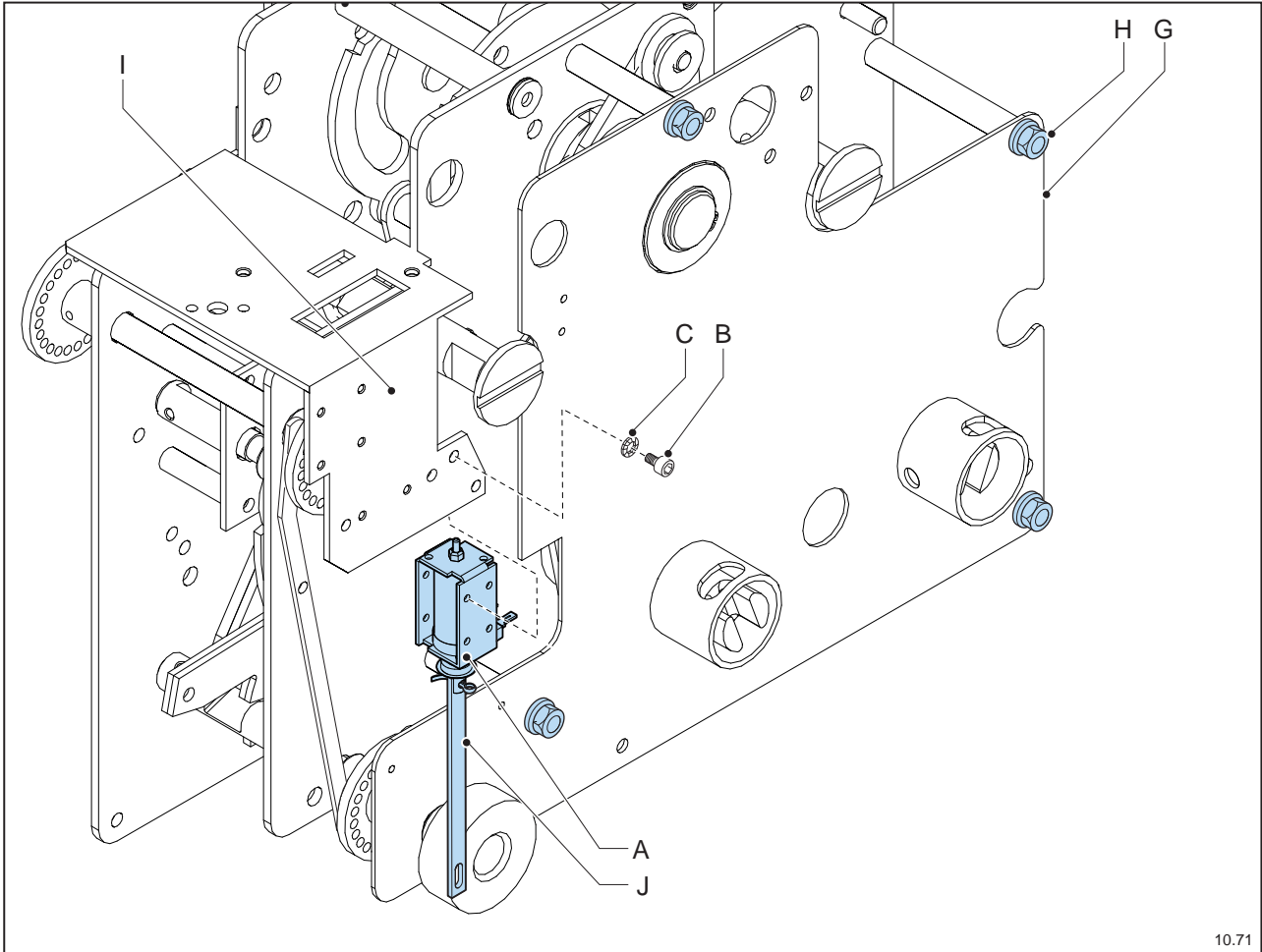

10.71

- Dismount the front plate (fig. 10.71G):
  - Loosen the four hexagonal tap bolts (fig. 10.71H).
  - Remove the front plate.
- Mount the completely pre-mounted shunt-trip release (fig. 10.71A):
  - Attach the shunt-trip release (top side) using the cylindrical screws (fig. 10.71B) and the lock washers (fig. 10.71C) behind the support plate (fig. 10.71I).  
The shaft (fig. 10.71J) of the shunt-trip release must point downwards.
  - Put the hexagonal tap bolt (fig. 10.72F) through the disc with the holes (fig. 10.72L).

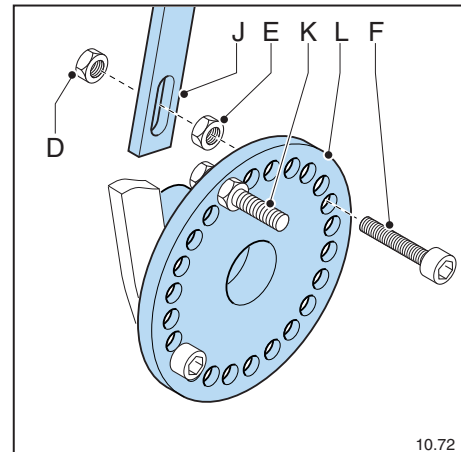

10.72



Leave between the already present hexagonal tap bolt (fig. 10.72K) and the newly to be mounted hexagonal tap bolt (fig. 10.72F) exactly five holes open.

- Place one of the two hexagon nuts (fig. 10.72E) on the threaded end of the just placed hexagon tap bolt.
- Tighten the hexagon nut against the disc.

- Place the end of the shaft of the shunt-trip release over the threaded end of the hexagon tap bolt. The shaft has a slotted hole for this.
- Mount the second hexagon nut (fig. 10.72D), with a bit of Loctite 270, on the threaded end of the hexagon tap bolt and turn the hexagon nut until about 3 mm of the hexagonal tap bolt protrudes. The shaft of the shunt-trip release rests now between both hexagon nuts.
- Check the operation of the shunt-trip release by pressing the shunt-trip release – with still opened load break switch - by hand. The shaft must be free and be able to move smoothly.

### 9.3.4.1.3 Electrical monitoring with external power source



Prevent burning out of the release. Break the voltage to the release of the load break switch is opened.

Place an auxiliary contact if supply comes from an external power source (battery). See “DP – Auxiliary contact(s) on the load break switch”.

- Mount the front plate using the four hexagonal tap bolts.

## 9.4 Under-voltage releases

Under-voltage releases can be mounted on the drive mechanism of cells with a fuse combination. With the help of these under-voltage releases the load break switch can be opened automatically and from a distance. It is possible to provide a DP-MEC with an under-voltage release without delay (direct opening).

### 9.4.1 Preparation for mounting

The following preparations must always be taken **before** you start mounting an under-voltage release:

- Make the entire medium voltage board voltage free.

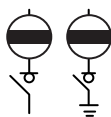

Open the particular cell as well as the load isolation and the earth switches.

- Dismount the front panel:
  - Loosen the four hexagonal tap bolts (fig. 10.01C)
  - Remove the four washers (fig. 10.01B).
  - Remove the front panel (fig. 10.01A).

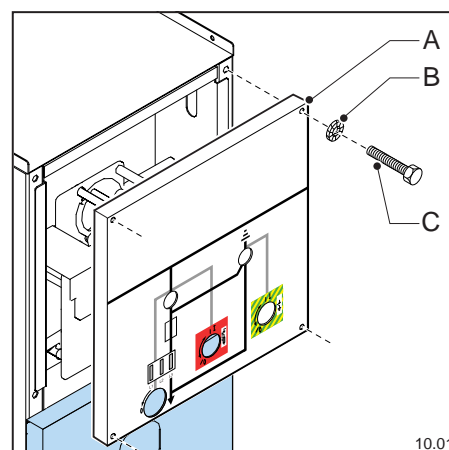

10.01

### 9.4.2 Mounting of under-voltage releases - general

Special mounting kits are available for mounting under-voltage releases. For further information and detailed mounting instructions **for each specific mounting kit**, see “Mounting of under-voltage releases – specific (for each drive mechanism)”



Mounting under-voltage releases without delay is done in the same way as the mounting of under-voltage releases with delay, except for the setting of the time delay.

### 9.4.3 Final checking and commissioning

The following actions must always be carried out **after** mounting the under-voltage release:

- Check that the fitting materials are properly attached.
- Electrically connect the under-voltage release.
- Measure the under-voltage release using a multimeter. If the under-voltage release is supplied by an external power source, an auxiliary contact must always be placed to protect the under-voltage release.
- Mount the front panel.
- Put the particular cell into operation: earth switch (if present) OPEN, load break switch CLOSED.
- Put the medium voltage board back into operation.

### 9.4.4 Mounting of under-voltage releases – specific (for each drive mechanism)

#### 9.4.4.1 DP, DP-M, DP-A, DP-A-M – Under-voltage release delayed with minutia on the load break switch

Special mounting kits are available for mounting an under-voltage release. The composition of these mounting kits may vary to some extent, depending on the release type.

##### 9.4.4.1.1 Available release types

order number	description
OP310024	assembled under-voltage releases with time delayed, 24 VDC/DP
OP310048	assembled under-voltage releases with time delayed, 48 VDC/DP
OP310110	assembled under-voltage releases with time delayed, 110 VDC/DP
OP311024	assembled under-voltage releases with time delayed, 24 VAC/DP
OP311048	assembled under-voltage releases with time delayed, 48 VAC/DP
OP311110	assembled under-voltage releases with time delayed, 110 VAC/DP
OP311230	assembled under-voltage releases with time delayed, 230 VAC/DP

- See following table.

order number	description	number	pos. no.
OP301230	assembled under-voltage releases with minutia, 230 VAC/DP	1	fig. 10.73A
GR040972	self-locking cylindrical screw, socket, M6x10, RIPP	2	fig. 10.73B

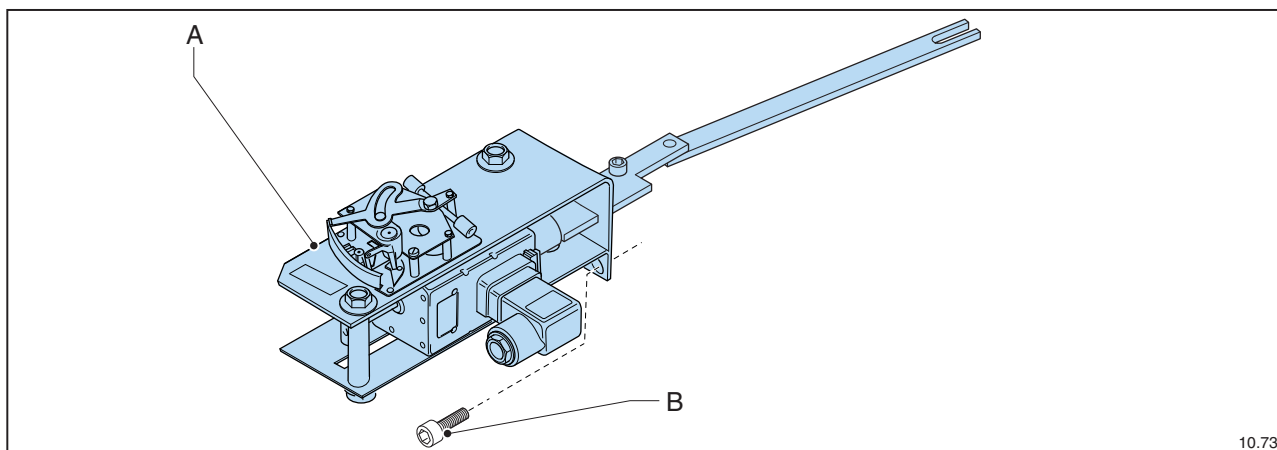

#### 9.4.4.1.2 Mounting instructions



For preparing and finishing work, see “Preparation for mounting” and “Final check and commissioning” respectively.

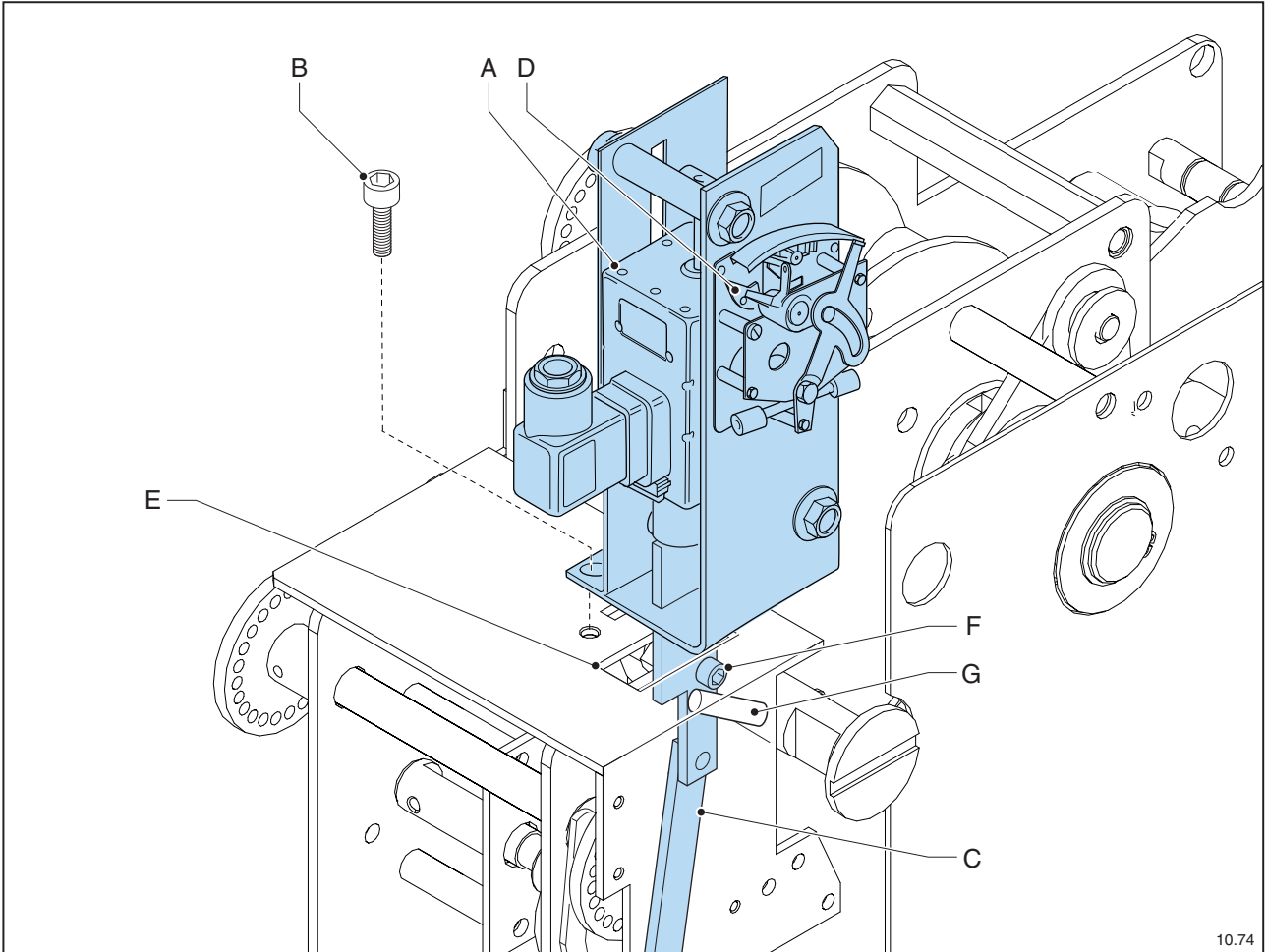

- Mount the completely pre-assembled under-voltage release (fig. 10.74A):
  - Hold the under-voltage release with the minugia (fig. 10.74D) to the front side.
  - Slide the trip-out lath through the slot (fig. 10.74E) into the support plate.



Make sure that the cylindrical screw (fig. 10.74F) rests exactly on the elastic copille (fig. 10.74G).

- Mount the under-voltage release on the support plate using the cylindrical screws (fig. 10.74B).
- Dismount the locking nut (fig. 10.75J) at the bottom side of the trip-out lath (fig. 10.75D).
- Slide the forked end of the trip-out lath over the hexagon bolt (fig. 10.75I).
- Mount the lock nut and screw the lock nut about 2 mm on the threaded end.

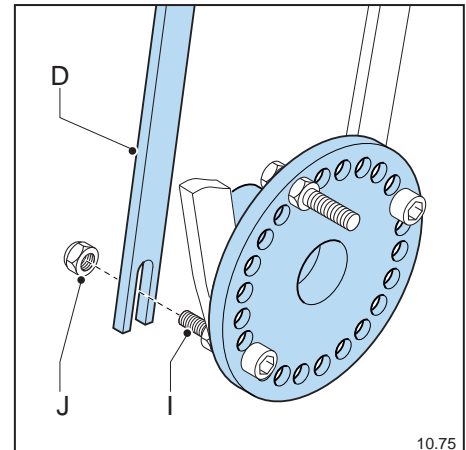

- Set the delay of the under-voltage release:
  - Turn the handle (fig. 10.77A) left or right.  
Handle fully left: no delay  
Handle fully right: delay of 3 or 4 seconds.
- Check the operation of the under-voltage release.

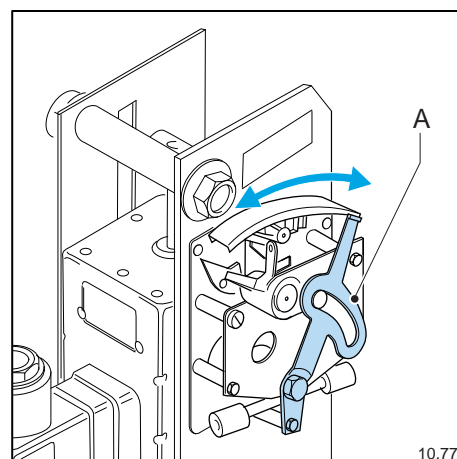

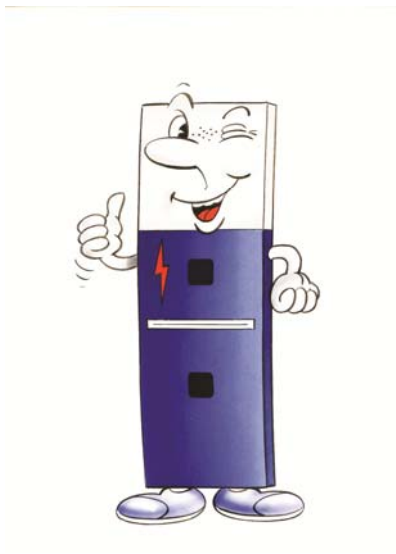

THE SPECIALIST IN **MEDIUM VOLTAGE SWITCHGEAR**